

Letter of Transmittal
Sir Sandford Fleming College
School of Environmental and Natural Resource Sciences
Frost Campus, PO Box 8000
Lindsay, ON K9V 5E6



Attention:

Rob Stavinga, Watershed Resources Technician, Kawartha Region Conservation Authority
Sara Kelly, Credit for Product II Faculty Supervisor

Subject: Kawartha Region Conservation Authority Bird Box Project

Dear Mr. Stavinga and Ms. Kelly,

The accompanying document entitled "Kawartha Region Conservation Authority Bird Box Implementation Report for Ken Reid Conservation Area" is submitted in accordance with the proposal and project plan agreed upon in January 2014. The deliverables outlined in the above documentation are presented in this document.

The purpose of the implementation report is to highlight the results of our research on bird box requirements and habitats at Ken Reid Conservation Area. We walked all the trails on the property and took note of all habitat types and determined seven target cavity-nesting species. We determined suitable habitat types for all of the seven species and created target habitat maps for each species. The implementation report was created as a tool for the implementation of bird boxes at Ken Reid and all other Kawartha Region Conservation Authority areas. Our team focused on making the report easy to understand and professional in nature.

We would like to thank Rob Stavinga for his guidance and support. We are grateful for the opportunity to work with you as we developed our project management skills. We would also like to thank Sara Kelly for the support throughout the project and for organizing great partnerships with the college.

Thank you,

Reid Bentzen
reidbentzen@gmail.com
EM Student

Robin Brand
robin.brand@flemingcollege.ca
EM Student

Whitney Brennan
whitney.brennan@flemingcollege.ca
EM Student

Sarah Sinasac
sarah.sinasac@flemingcollege.ca
EM Student

Kawartha Region Conservation Authority Bird Box Implementation Report for Ken Reid Conservation Area

Credit for Product II

Presented to:

Rob Stavinga, Kawartha Region Conservation Authority



**KAWARTHA
CONSERVATION**

and

Sara Kelly, Faculty; Ecosystems Management Technology, School of Environment
and Natural Resource Sciences, Sir Sandford Fleming College
Created for Kawartha Region Conservation Authority



**School of Environmental &
Natural Resource Sciences**

Frost Campus | Fleming College

Created by:

Reid Bentzen

Robin Brand

Whitney Brennan

Sarah Sinasac

Executive Summary for Kawartha Region Conservation Authority Bird Box Implementation Project

This report aims to provide steps for the creation and implementation of bird boxes in Ken Reid Conservation area. The Kawartha Region Conservation Authority's mission is to provide leadership in conservation and therefore wishes to help conserve cavity nesting species. These species of birds are an important part of maintaining and restoring aquatic and terrestrial ecosystems. Secondary cavity nesters are at risk of habitat loss due to loss of old growth forests. Young forests do not have as many cavity options as older forests do, and cavity nesters are not able to find suitable nests. This report provides the baseline for implementation of bird boxes in all of Kawartha Region Conservation Authority's conservation areas. Kawartha Region Conservation Authority partnered with Fleming College's Ecosystem Management Technology Program's Credit for Product course to provide an opportunity for students to create this bird box implementation report for Ken Reid Conservation Area. The implementation report outlines mapping and bird box design for seven target species and funding opportunities for the project.

Key Findings and Conclusions

The implementation report required research on cavity nesting species. Some of the key results were focused around common species such as black-capped chickadees, and rarer species such as Eastern bluebirds. Some of the key findings include the following:

- Standard nest structures were rarely used by chickadees even when filled with wood shavings. Instead of standard nest boxes, chickadees appear to prefer artificial tree snags made of PVC pipe. Chickadees typically excavate 60–70 percent of artificial snags and only 40–50 percent of nest boxes.
- Eastern bluebirds were found to prefer east and north facing boxes, and boxes that were facing in an eastern direction fledged more young than boxes facing in other directions.
- Wood ducks were found to prefer management impoundments and lake-influenced wetland habitats. Wetlands contribute to the nutritional demands of breeding female wood duck and nesting habitats that are less than 0.5 kilometers from wetland or shoreline.

Key recommendations

High priority, medium priority and low priority habitats were determined using ELC data and personal visits to Ken Reid. The high priority areas were determined to be in the north-east section near the old beach (refer to Figure 9). The medium priority area was determined to be the Point Trail (refer to Figure 9). The low priority area was determined to be along the Woodland Trail (refer to Figure 9). The implementation report should be used by all of Kawartha Region Conservation Authority's properties to conserve secondary cavity-nesting species and provide optimal habitat locations for the target species.

Table of Contents

- 1.0 Introduction 7**
 - 1.1 Purpose..... 7
 - 1.2 Project Goals..... 7
 - 1.3 Project Design..... 8
- 2.0 Habitat Requirements 8**
 - 2.1 Black-capped Chickadee - *Poecile atricapillus*..... 8
 - 2.2 Eastern Bluebird - *Sialia sialis*..... 8
 - 2.3 Eastern Screech-Owl - *Megascops asio* 9
 - 2.4 Northern Saw-Whet Owl - *Aegolius acadicus* 9
 - 2.5 Wood Duck - *Aix sponsa* 9
 - 2.6 Tree Swallow - *Tachycineta bicolor* 9
 - 2.7 Northern Flicker - *Colaptes auratus* 9
- 3.0 Bird Box Design..... 9**
- 4.0 Installation 10**
- 5.0 Trail Box Implementation 11**
 - 5.1 Black-capped Chickadee 12
 - 5.2 Eastern Bluebird..... 14
 - 5.3 Eastern Screech Owl..... 16
 - 5.4 Northern Saw-whet Owl..... 18
 - 5.5 Wood Duck..... 20
 - 5.6 Tree Swallow 22
 - 5.7 Northern Flicker 24
 - 5.8 Ken Reid Conservation Area Priority Installation Sites..... 26
 - 5.9 Interpretive Signage Implementation..... 28
- 6.0 Monitoring and Maintenance 29**
 - 6.1 Monitoring Programs..... 29
 - 6.2 Disturbances 30
- 7.0 Funding 30**
 - 7.1 Material Funding..... 31
 - 7.2 Monetary Funding 32
 - 7.3 Volunteer Sources 33
- 8.0 References 34**
- 9.0 Appendix..... 35**
 - 9.1 Appendix A: Nest Box Plans 35**
 - Black-capped Chickadee 35
 - Eastern Bluebird & Tree Swallow 36
 - Eastern Screech Owl & Northern Saw-whet Owl..... 37
 - Wood Duck..... 38
 - Northern Flicker 39
 - 9.2 Appendix B: Predator Guards 40**
 - Conical Predator Guard 40
 - Stovepipe Predator Guard..... 41

| | |
|---|-----------|
| Noel Predator Guard..... | 42 |
| 9.3 Appendix C: Ken Reid Conservation Area Trail Map | 43 |
| 9.4 Appendix D: Cornel Nest Watch Monitoring Protocol | 44 |
| 9.5 Appendix E: Project Plan..... | 45 |
| 9.6 Appendix F: Progress Report..... | 48 |
| 9.7 Appendix G: Literature Reviews..... | 55 |
| Literature Review 1: Potential Disturbances Affecting Cavity Nesting Birds..... | 55 |
| Literature Review 2: Artificial Nesting Structure Construction and Placement..... | 59 |
| Literature Review 3: Habitat Requirements of Cavity Nesters..... | 63 |
| Literature Review 4: Monitoring Bird Boxes..... | 69 |

Table of Tables

| | |
|--|----|
| Table 1: Nest Box Design Specifications..... | 9 |
| Table 2: Priority Scale for Established Habitats..... | 11 |
| Table 3: Black-capped Chickadee Priority Habitat Descriptions..... | 13 |
| Table 4: Eastern Bluebird Priority Habitat Descriptions | 15 |
| Table 5: Eastern Screech Owl Priority Habitat Descriptions | 17 |
| Table 6: Northern Saw-whet Owl Priority Habitat Descriptions | 19 |
| Table 7: Wood Duck Priority Habitat Descriptions | 21 |
| Table 8: Tree Swallow Priority Habitat Descriptions | 23 |
| Table 9: Northern Flicker Priority Habitat Descriptions..... | 25 |
| Table 10: Ken Reid Conservation Area Priority Habitat Descriptions | 27 |
| Table 11: Potential Funding Sources..... | 30 |

Table of Figures

| | |
|---|----|
| Figure 1: Flow Chart Demonstrating Implementation Plan | 8 |
| Figure 2: Black-capped Chickadee established nesting habitats in Ken Reid demonstrating high, medium, and low priority implementation habitats..... | 12 |
| Figure 3: Eastern bluebird established nesting habitats in Ken Reid demonstrating high, medium, and low priority implementation habitats. | 14 |
| Figure 4: Eastern screech owl established nesting habitats in Ken Reid demonstrating high, medium, and low priority implementation habitats. | 16 |
| Figure 5: Northern saw-whet owl established nesting habitats in Ken Reid demonstrating high, medium, and low priority implementation habitats..... | 18 |
| Figure 6: Wood duck established nesting habitats in Ken Reid demonstrating high, medium, and low priority implementation habitats. | 20 |
| Figure 7: Tree swallow established nesting habitats in Ken Reid demonstrating high, medium, and low priority implementation habitats. | 22 |
| Figure 8: Northern flicker established nesting habitats in Ken Reid demonstrating high, medium, and low priority implementation habitats. | 24 |
| Figure 9: Overall established nesting habitats in Ken Reid demonstrating high, medium, and low priority implementation habitats for all seven species being evaluated. | 26 |
| Figure 10: Interpretive signage locations for nest boxes within Ken Reid Conservation Area | 28 |
| Figure 11: Black-capped chickadee PVC nesting tube..... | 35 |

Figure 12: Eastern bluebird and tree swallow wood nest box plan..... 36
Figure 13: Eastern screech owl and northern saw-whet owl nest box plan..... 37
Figure 14: Wood duck nest box plan 38
Figure 15: Northern flicker nest box plan 39
Figure 16: Conical predator guard construction and installation plan..... 40
Figure 17: Stovepipe predator guard construction and implementation plan 41
Figure 18: Noel predator guard construction and implementation plan..... 42
Figure 19: Trail map for Ken Reid Conservation Area 43
Figure 20: Sample monitoring data sheet provided by Cornell Nest Watch..... 44

1.0 Introduction

Ken Reid Conservation Area is a 110 hectare natural habitat located just north of Lindsay, Ontario. It is the flagship conservation area for Kawartha Region Conservation Authority and has many kilometers of trails where visitors can enjoy hiking, bird watching, cross-country skiing, and many other outdoor activities. The conservation area has many types of ecosystems within it and is home to many species of animals and plants. Kawartha Region Conservation Authority is a leader in conservation and aims to help conserve all species found within their property.

Kawartha Region Conservation Authority is very concerned with the status of cavity nesting birds within the Kawartha region. Cavity nesting birds are among the most threatened birds in North America due to habitat loss. Woodpeckers are primary excavators, which excavate a new cavity for nesting each year; their old unused cavities are then used by cavity nesting species such as ducks, owls and other birds. The presence of dead or dying trees suitable for cavity excavation is the single most important factor limiting the numbers of cavity nesting birds (James, 1984). Artificial nesting structures can be used to mitigate the loss of natural cavities and increase the reproductive success for cavity nesting birds by increasing the number of suitable nesting sites.

This report was created by students from Sir Sandford Fleming College, in the Ecosystem Management Technology program. Kawartha Region Conservation Authority partnered with Fleming College through Ecosystem Management's Credit for Product Course. Four students were chosen to determine suitable cavity nesting habitat at Ken Reid Conservation Area and write this implementation report for a list of target species. This report was written by Reid Bentzen, Robin Brand, Whitney Brennan, and Sarah Sinasac.

1.1 Purpose

This implementation report aims to provide information for building and installing artificial nesting structures in suitable habitat within the Kawartha Region Conservation Authority areas. The implementation report is specific to Ken Reid Conservation Area but may be modified for all other conservation areas. This report aims to work with the Kawartha Region Conservation Authority's mission to provide leadership with conservation, by helping to provide healthy habitat for Kawartha Region's cavity nesting birds. Due to anthropogenic development, many suitable habitat areas have been lost or modified, ultimately causing many cavity nesting species to struggle to find suitable nesting habitat. Cavity nesting species are important in regard to maintaining and restoring terrestrial and aquatic habitat within the Kawartha watersheds, and should be considered when creating conservation plans.

1.2 Project Goals

This project aims to build and install bird boxes within suitable habitat areas in the conservation areas. In order to reach this goal, target species must be identified, and habitat and nest box requirements need to be determined for each of the key species. The final goal of this project is to aid in the conservation of cavity nesting species that are at risk of habitat loss.

1.3 Project Design

The first step to this process was to determine habitat types within the conservation area, and to identify cavity nesting species which could live within each habitat. A list of target species was then established. Maps were created using ArcGIS software to determine suitable areas within the conservation area for each target species. Bird box building requirements were determined and blueprints for the boxes were obtained from the Cornell Lab of Ornithology. Installation requirements were determined, ie. height from ground, distance from other boxes, orientation etc. Finally, bird boxes were built and erected within their outlined suitable habitats. Monitoring programs were set up in order to ensure that the boxes remained intact, and were occupied by the target species. Details of all the steps are included in this implementation report. This implementation report can be used as a baseline document for bird box projects within all Kawartha Region Conservation Authority areas.

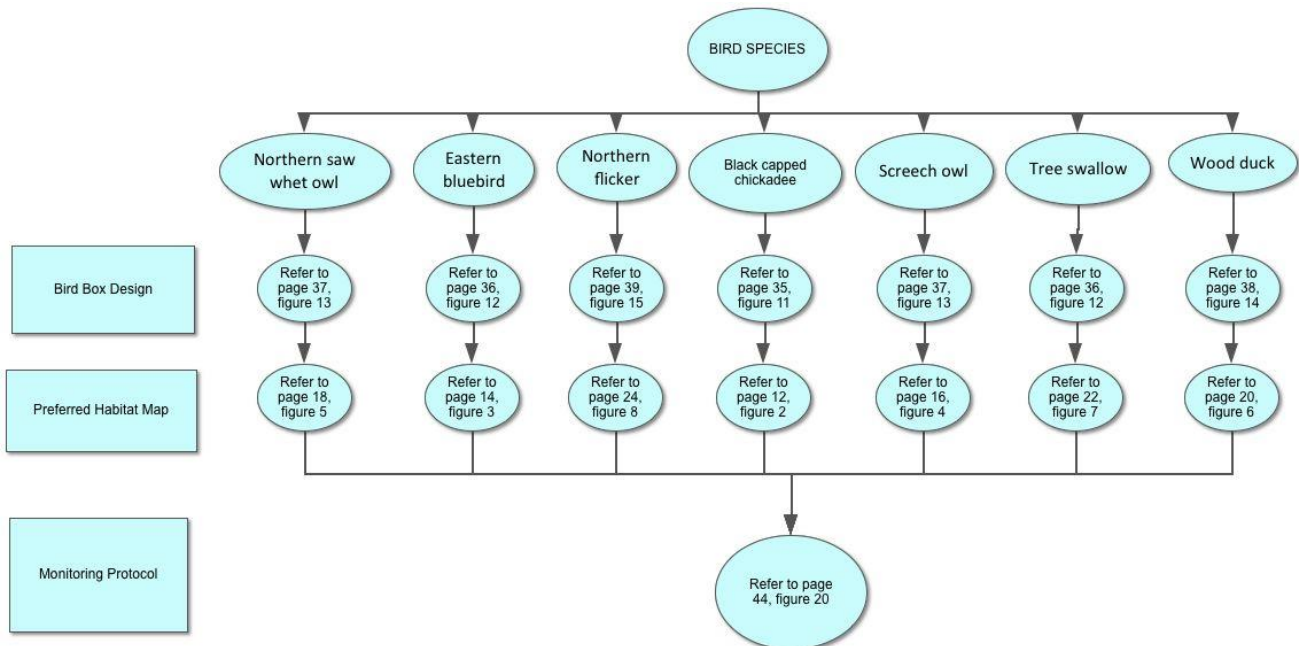

Figure 1: Flow Chart Demonstrating Implementation Plan

2.0 Habitat Requirements

Knowledge of target species natural history is incredibly important and is essential for the success of artificial nesting structures. The main consideration in placement of nest boxes is the target species and their habitat/ nesting requirements. Suitable habitat for cavity nesting birds must provide adequate habitat for feeding and roosting throughout the year.

2.1 Black-capped Chickadee - *Poecile atricapillus*

Black-capped Chickadees inhabit deciduous and mixed forests, open woods, parks, and willow thickets. Both male and female chickadees will excavate a cavity (often in birch or alder trees) up to 21cm deep.

2.2 Eastern Bluebird - *Sialia sialis*

Eastern Bluebirds inhabit open country around trees with little understory and sparse ground cover. they are common along pastures, agricultural fields as well as suburban parks. Bluebirds nest in natural

cavities (woodpecker holes in dead pine or oak trees) or in nest boxes or other artificial refuges.

2.3 Eastern Screech-Owl - *Megascops asio*

Eastern Screech-Owls inhabit both coniferous and deciduous forests particularly near water however they will only nest in deciduous trees. Eastern Screech- Owls do not dig a cavity themselves; they depend on tree holes opened or enlarged by woodpeckers, fungus, rot, or squirrels.

2.4 Northern Saw-Whet Owl - *Aegolius acadicus*

Northern Saw Whet Owls prefer mature forests with an open understory for foraging and deciduous trees for nesting with water habitat nearby. Females choose a nest site in previously excavated holes or in nest boxes.

2.5 Wood Duck - *Aix sponsa*

Wood ducks thrive in bottomland forests, swamps, and freshwater marshes. Typically nest in cavities where a branch has broken off and the tree’s heartwood has rotted.

2.6 Tree Swallow - *Tachycineta bicolor*

Tree Swallows inhabit fields, marshes, shorelines, and wooded swamps preferring to live in proximity to water. Tree swallows nest in natural cavities of standing dead trees, old woodpecker cavities or in nest boxes. The nest is made of grasses and aquatic plants.

2.7 Northern Flicker - *Colaptes auratus*

Northern Flickers inhabit woodlands, forest edges, open fields with scattered trees, as well as flooded swamps and marsh edges. Both males and females excavate a tree cavity (often trembling aspen due to easy excavation) 13- 16 inches deep.

3.0 Bird Box Design

There are over 80 cavity nesting species that are candidates for artificial nesting structures. It has been determined that certain species are most likely to use nest boxes of a specific size and design, and have the best reproductive success. Table one summarizes the building requirements for each of the target species for Ken Reid Conservation Area.

Table 1: Nest Box Design Specifications

| Species | Entrance Hole Diameter | Entrance Hole Height | Floor Dimensions | Total Height of Box | Height Above Ground / Water | Figure Number | Comments |
|------------------------|------------------------|----------------------|------------------|---------------------|-----------------------------|---------------------|---|
| Black-capped Chickadee | 1.0 - 1.5 | 6 - 7 | 4x4 - 5x5 | 9 - 12 | 6 - 15 | Appendix A Figure 1 | Prefer to nest in birch or alder trees. Nest boxes should be filled with wood shavings or saw dust. Boxes should be placed 60 feet into a wooded area to keep |

| | | | | | | | |
|-----------------------|------------|---------|--------------------|---------|--------------------|---------------------|---|
| | | | | | | | wrens out of boxes. Should have 1 box per 10 acres . |
| Eastern Bluebird | 1.5 | 6 - 7 | 4x4 | 11- 12 | 5 - 10 3-6 feet | Appendix A Figure 2 | Entrance hole should face the east. Boxes should be 300 feet apart. |
| Eastern Screech Owl | 2.5 - 4.0 | 10 - 12 | 6x6 - 8x8 | 15 - 18 | 10 - 30 | Appendix A Figure 3 | Do not actually build a nest just lays eggs on whatever is in the bottom of the cavity. Can place wood chips in the bottom of the box. Entrance should be facing north. Boxes should be 100 feet apart. |
| Northern Saw Whet Owl | 2.5 - 4.0 | 10 - 12 | 6x6 - 8x8 | 15 - 18 | 10 - 30 | Appendix A Figure 3 | Use leaves or wood chips in the bottom of the box, never use sawdust. Use rough lumber so that the chicks can grip the inside of the box in order to get out. |
| Wood Duck | 3.0 - 4.0 | 16 - 18 | 10 x 10 - 12x12 | 25 - 25 | 10 - 20 | Appendix A Figure 4 | Nest box should be placed over water where possible. Nest boxes should be 600 feet apart |
| Tree Swallow | 1.25 - 1.5 | 6 - 7 | 4x4 - 5x5 | 9 - 12 | 5 - 15 | Appendix A Figure 3 | Nest box should be 100 ft from water. Entrance hole should face east and nest boxes should be at least 30 feet apart |
| Northern Flicker | 2.0 - 3.0 | 10 - 20 | 6x6 - 8x8 | 14 - 24 | 6- 20 | Appendix A Figure 5 | Nest box should be filled with wood shavings. Prefer to nest in trembling aspen. Entrance hole facing southeast. 200ft between nestboxes |

4.0 Installation

Artificial nesting structures should be installed well before the breeding season preferably in mid to late march. Although nest boxes provide nesting opportunities for many native birds they also make easy targets for predators. Common predators that take advantage of nest boxes include raccoons, cats, snakes and squirrels. To limit exposure to these predators placing boxes in thick vegetation should be avoided when possible as branches can allow predators to access the box. Roofs should also be installed that extend 5 inches beyond the front of the box to prevent predators from easily reaching into the nest box entrance hole. Nest boxes can be mounted on metal poles, fence posts, or on trees. Mounting on metal poles is the best option as boxes can be mounted higher than on fence posts and are harder for predators to climb. Nesting structures, which, are mounted on poles, should have a metal cone predator guard with marine grease (Figure 16 in Appendix B). Boxes mounted on trees and fence posts should have a 3ft wide strip of galvanized metal or stovepipe wrapped around the trunk beneath the box secured with nails (Figure 17 Appendix B). Noel predator guards are rectangular tubes of hardware cloth, which are stapled to the front of the nest box around the entrance hole (Figure 18 in Appendix B). This makes it difficult for predators to reach into the box but still allows the nesting birds to

easily enter and exit the nest box.

5.0 Trail Box Implementation

To select the most optimal nesting habitats for cavity nesters in Ken Reid, priority habitats for implementing nest boxes were determined for each of the seven cavity nesting species. The priority scale was determined through the use of a variety of parameters selected during site evaluations. Through these parameters, suitable implementation habitats were established throughout Ken Reid Conservation Area for seven species of cavity nesters.

Table 2: Priority Scale for Established Habitats

| Parameter | High Priority Value (3) | Medium Priority Value (2) | Low Priority Value (1) |
|--|--|---|--|
| Amount of Disturbance | | | |
| Proximity to dog park | Greater than 100m | 50m – 100m | Less than 50m |
| Proximity to walking trail | Greater than 15m | 5m – 15m | Less than 5m |
| Proximity to roadway | Greater than 20m | 10m – 20m | Less than 10m |
| Foraging Habitats | | | |
| Proximity to suitable feeding habitat | Less than 50m | 50m – 100m | Greater than 100m |
| Food availability | Maximum vegetation for foraging | Moderate vegetation for foraging | Minimal vegetation in habitat for foraging |
| Habitat Requirements (Refer to Specie Requirements) | | | |
| Habitat suitability | Maximum nesting habitat vegetation | Moderate nesting habitat vegetation | Minimal nesting habitat vegetation |
| Habitat availability | Maximum amount of vegetation to support a healthy population number of species | Moderate amount of vegetation to support a healthy population number of species | Minimal amount of vegetation to support a healthy population number of species |

The parameters selected to establish ideal cavity nesting habitats were thought to be the most optimal variables for establishing beneficial habitats. Through the use of this priority scale, values for optimal nesting habitats were determined for the seven species being evaluated. High, medium, and low priority nesting habitats throughout Ken Reid were established by evaluating the priority scale values obtained through site evaluations. High priority habitats were determined by the maximum foraging and nesting habitat requirements being provided within and surrounding the established habitat, with minimal human disturbances to promote successful nesting habitats to contribute to specie reproductive success. While low priority habitats were determined by the minimal foraging and nesting habitat requirements being provided within and surrounding the established habitat that contain maximum human disturbances.

Priority habitat descriptions below for seven species and map, refer to Figure 19 in Appendix C for a trail map of Ken Reid Conservation to provide more information on the location of selected nesting habitats.

5.1 Black-capped Chickadee

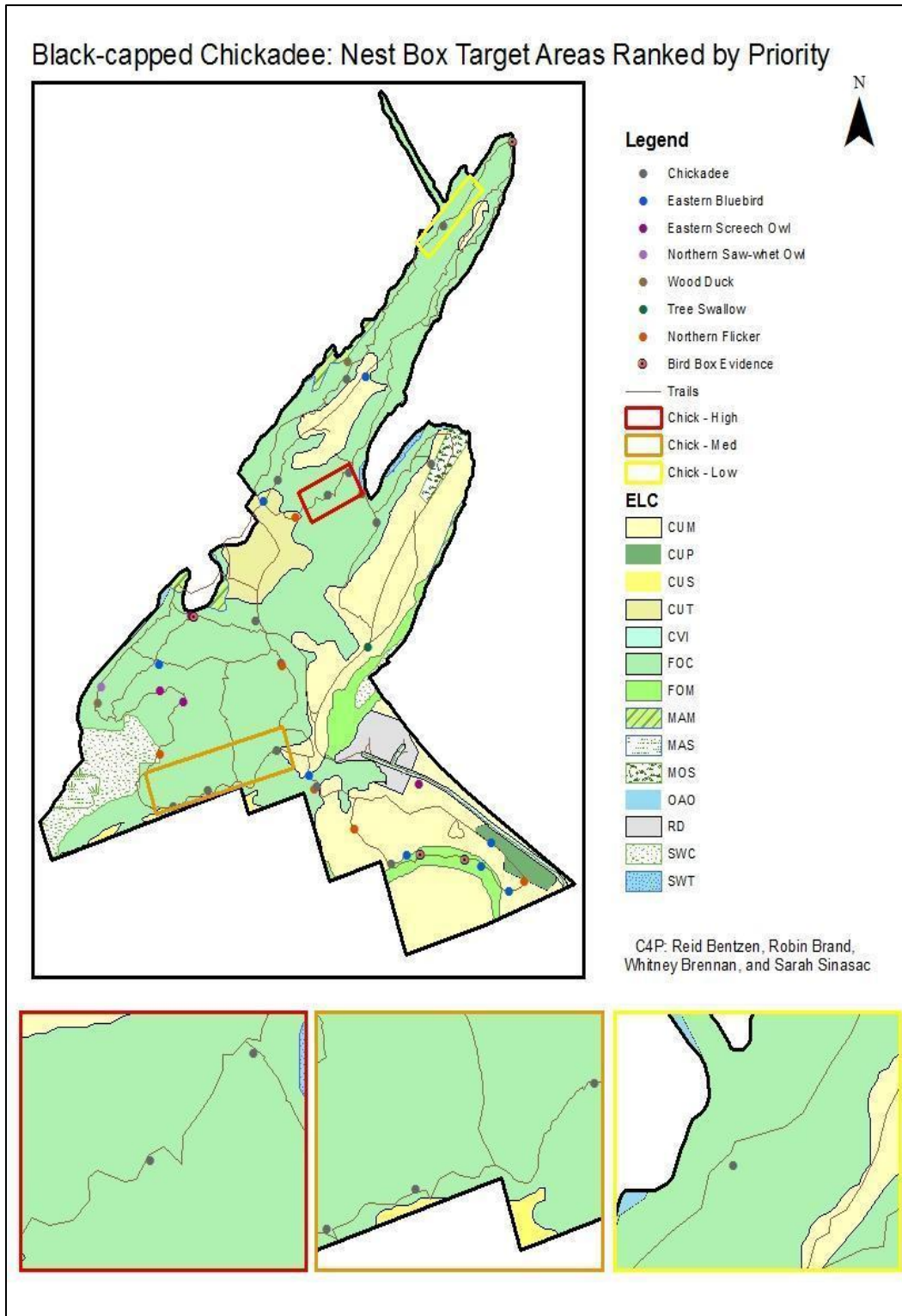

Figure 2: Black-capped Chickadee established nesting habitats in Ken Reid demonstrating high, medium, and low priority implementation habitats.

Through site evaluations, habitats were selected through the use of the priority scale to determine the maximum habitat value that will provide the greatest amount of benefits to promote reproductive success of black-capped chickadees. The recommended high priority habitat is located along the Camp Loop trail; the medium priority habitat is located along the Woodland and Rabbit Hollow trails; and the low proximity habitat is located along the Point Trail.

Table 3: Black-capped Chickadee Priority Habitat Descriptions

| Established Habitat | Priority Parameters |
|-------------------------|--|
| High Priority Habitat | <ul style="list-style-type: none"> • Minimal human disturbances due to other surrounding trails • Optimal foraging habitat and food availability • Nesting habitat within deciduous and mixed forest is provided with birch trees present |
| Medium Priority Habitat | <ul style="list-style-type: none"> • Habitat availability with some disturbances from walking trail • Nesting habitat provided within deciduous and mixed forest |
| Low Priority Habitat | <ul style="list-style-type: none"> • More available natural cavities for black-capped chickadee for established habitat • Nesting habitat provided in cedar forest |

5.2 Eastern Bluebird

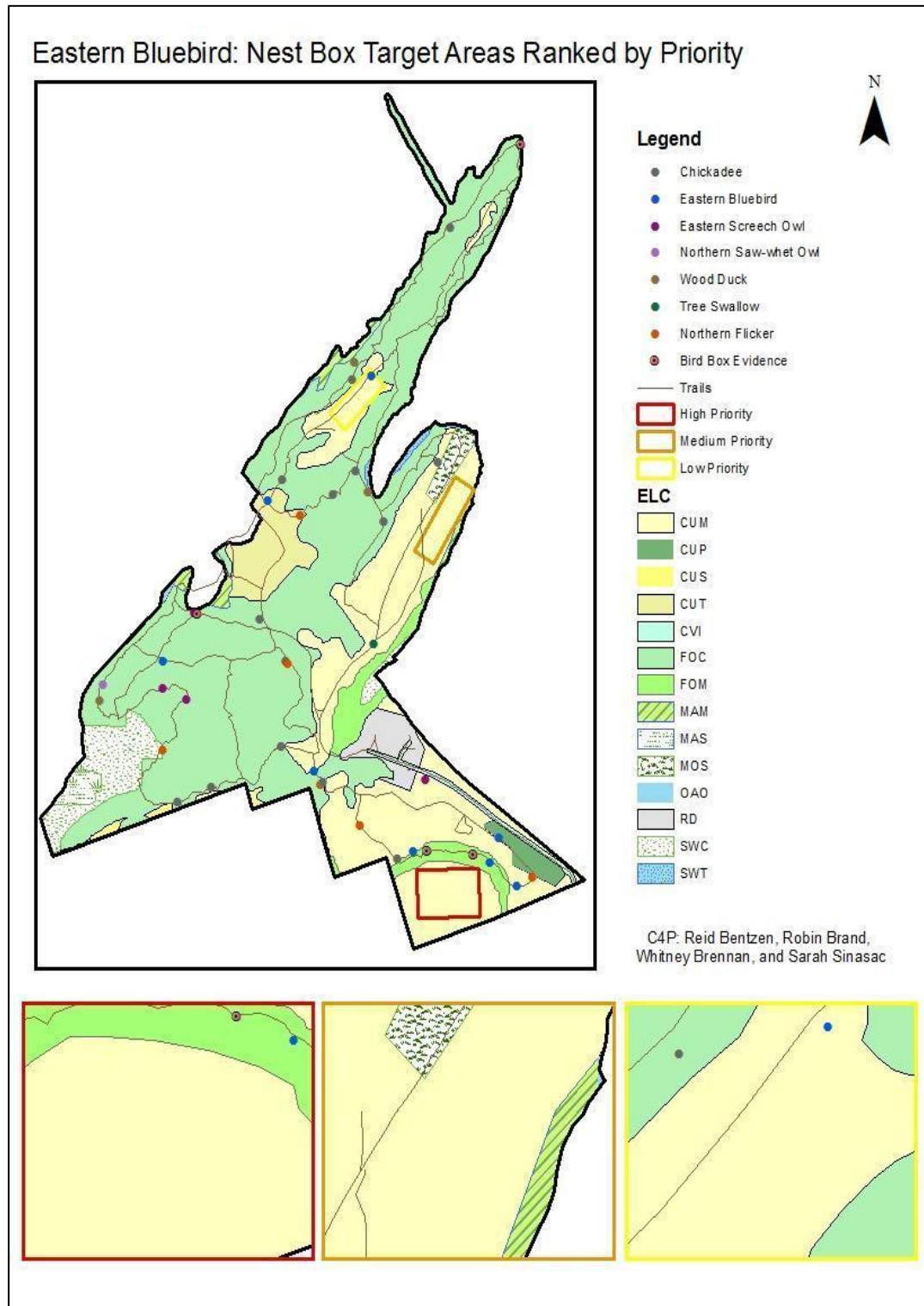

Figure 3: Eastern bluebird established nesting habitats in Ken Reid demonstrating high, medium, and low priority implementation habitats.

Through site evaluations, habitats were selected through the use of the priority scale to determine the maximum habitat value that will provide the greatest amount of benefits to promote reproductive success of eastern bluebirds. The recommended high priority habitat is located along the Escarpment Trail; the medium priority habitat is located along the Meadow Walk trail; and the low proximity habitat is located along the Point trail.

Table 4: Eastern Bluebird Priority Habitat Descriptions

| Established Habitat | Priority Parameters |
|-------------------------|---|
| High Priority Habitat | <ul style="list-style-type: none"> • Minimal human disturbances due to other surrounding trails • Optimal foraging habitat and food availability due to sumac trees and sparse ground cover • Maximum area for nesting habitats within sumac and along fence posts |
| Medium Priority Habitat | <ul style="list-style-type: none"> • Moderate human disturbance due to shelter and playground nearby • Meadow habitat with edge habitat from trees with minimal understory • Suitable foraging habitat |
| Low Priority Habitat | <ul style="list-style-type: none"> • Meadow within forest to allow for foraging habitat with edge habitat for nesting • Established habitat area is smallest region within habitat |

5.3 Eastern Screech Owl

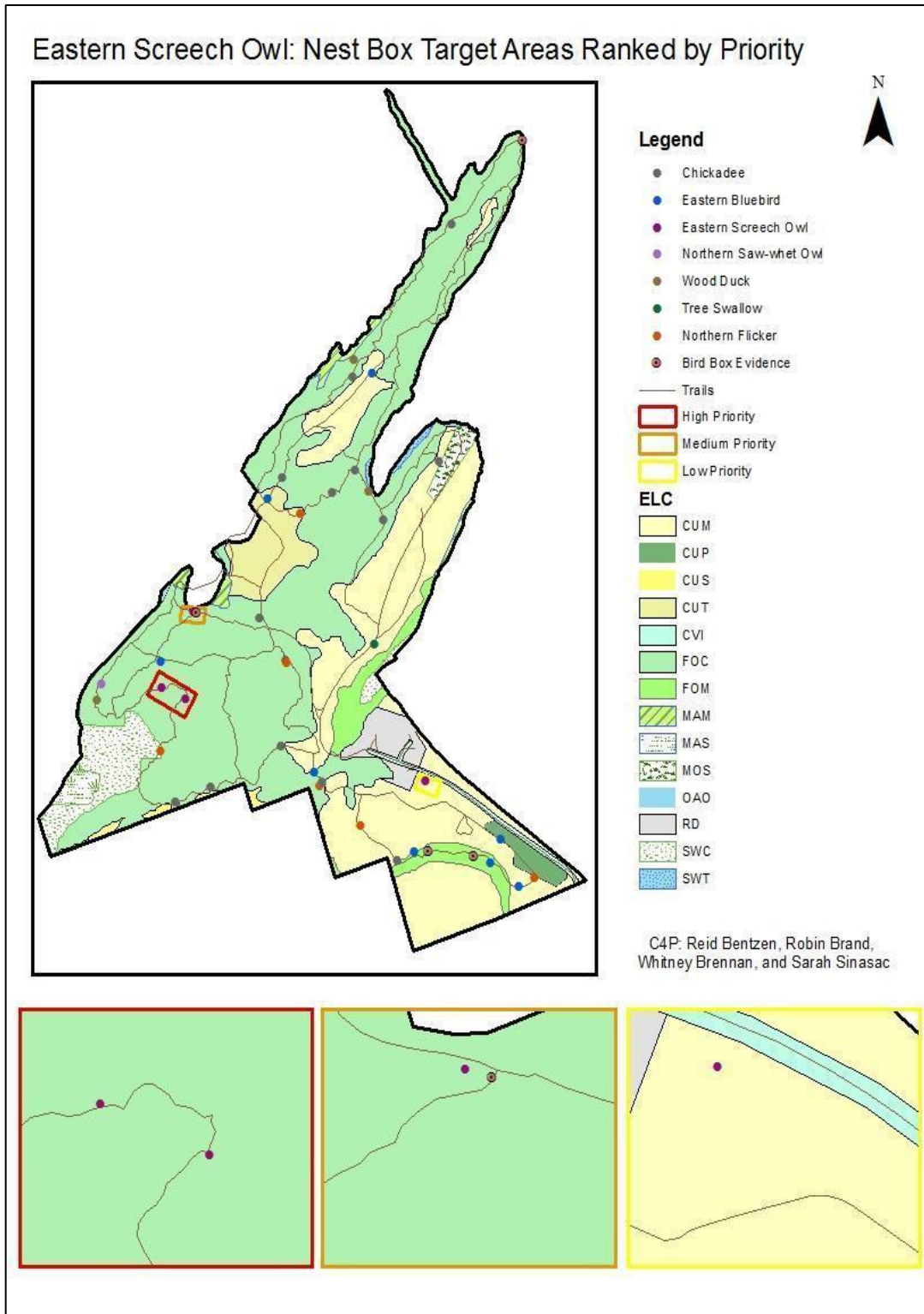

Figure 4: Eastern screech owl established nesting habitats in Ken Reid demonstrating high, medium, and low priority implementation habitats.

Through site evaluations, habitats were selected through the use of the priority scale to determine the maximum habitat value that will provide the greatest amount of benefits to promote reproductive success of eastern screech owls. The recommended high priority habitat is located along the Woodland Trail; the medium priority habitat is located along the Marsh Lookout trail; and the low proximity habitat is located along the Escarpment Trail.

Table 5: Eastern Screech Owl Priority Habitat Descriptions

| Established Habitat | Priority Parameters |
|-------------------------|---|
| High Priority Habitat | <ul style="list-style-type: none"> • Minimal human disturbances due to trail not as excessively utilized • Ideal nesting habitat within proximity to water body • Optimal foraging habitat with suitable understory in coniferous forest |
| Medium Priority Habitat | <ul style="list-style-type: none"> • Moderate human disturbances • Coniferous forest with some cavities available • Suitable foraging habitat within proximity to water |
| Low Priority Habitat | <ul style="list-style-type: none"> • Human disturbances due to proximity of dog park, road, and parking lot • Coniferous forest with open understory within proximity to field • Moderate foraging habitat |

5.4 Northern Saw-whet Owl

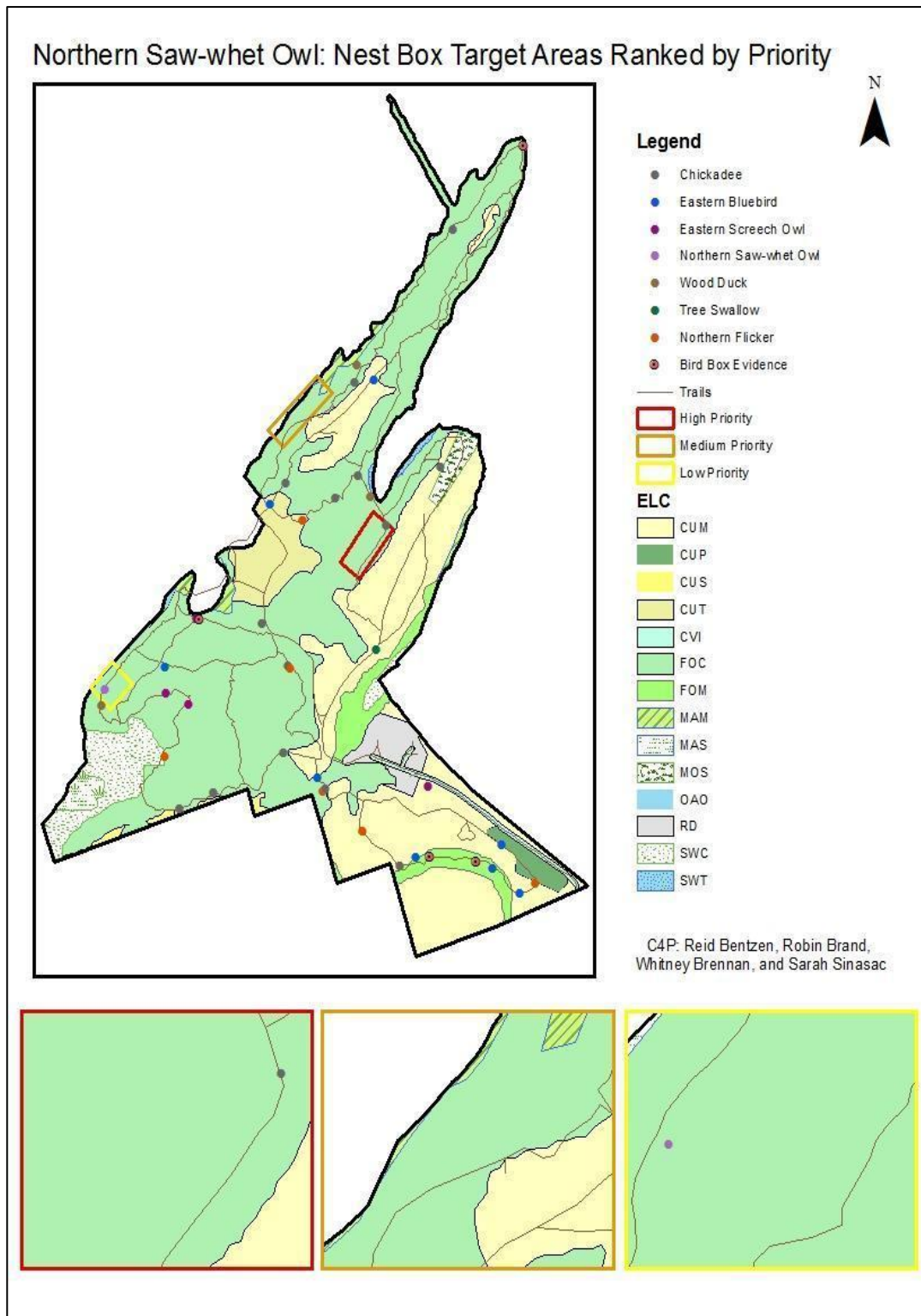

Figure 5: Northern saw-whet owl established nesting habitats in Ken Reid demonstrating high, medium, and low priority implementation habitats.

Through site evaluations, habitats were selected through the use of the priority scale to determine the maximum habitat value that will provide the greatest amount of benefits to promote reproductive success of northern saw-whet owls. The recommended high priority habitat is located along the Cedar Forest trail; the medium priority habitat is located along the Point and Camp Loop trails; and the low proximity habitat is located along the Trillium Pass trail.

Table 6: Northern Saw-whet Owl Priority Habitat Descriptions

| Established Habitat | Priority Parameters |
|-------------------------|---|
| High Priority Habitat | <ul style="list-style-type: none"> • Minimal human disturbances due to trail not as excessively utilized • Optimal foraging habitat and food availability with open understory • Proximity to water habitat • Ideal nesting habitat within cedar forest |
| Medium Priority Habitat | <ul style="list-style-type: none"> • Moderate human disturbances due to proximity of Victoria Rail Trail • Proximity to water for foraging and moderate foraging habitat • Moderate nesting habitat |
| Low Priority Habitat | <ul style="list-style-type: none"> • Greater human disturbance presence due to more trail access • Foraging habitat within proximity to water • Osprey nest in proximity to recommended habitat |

5.5 Wood Duck

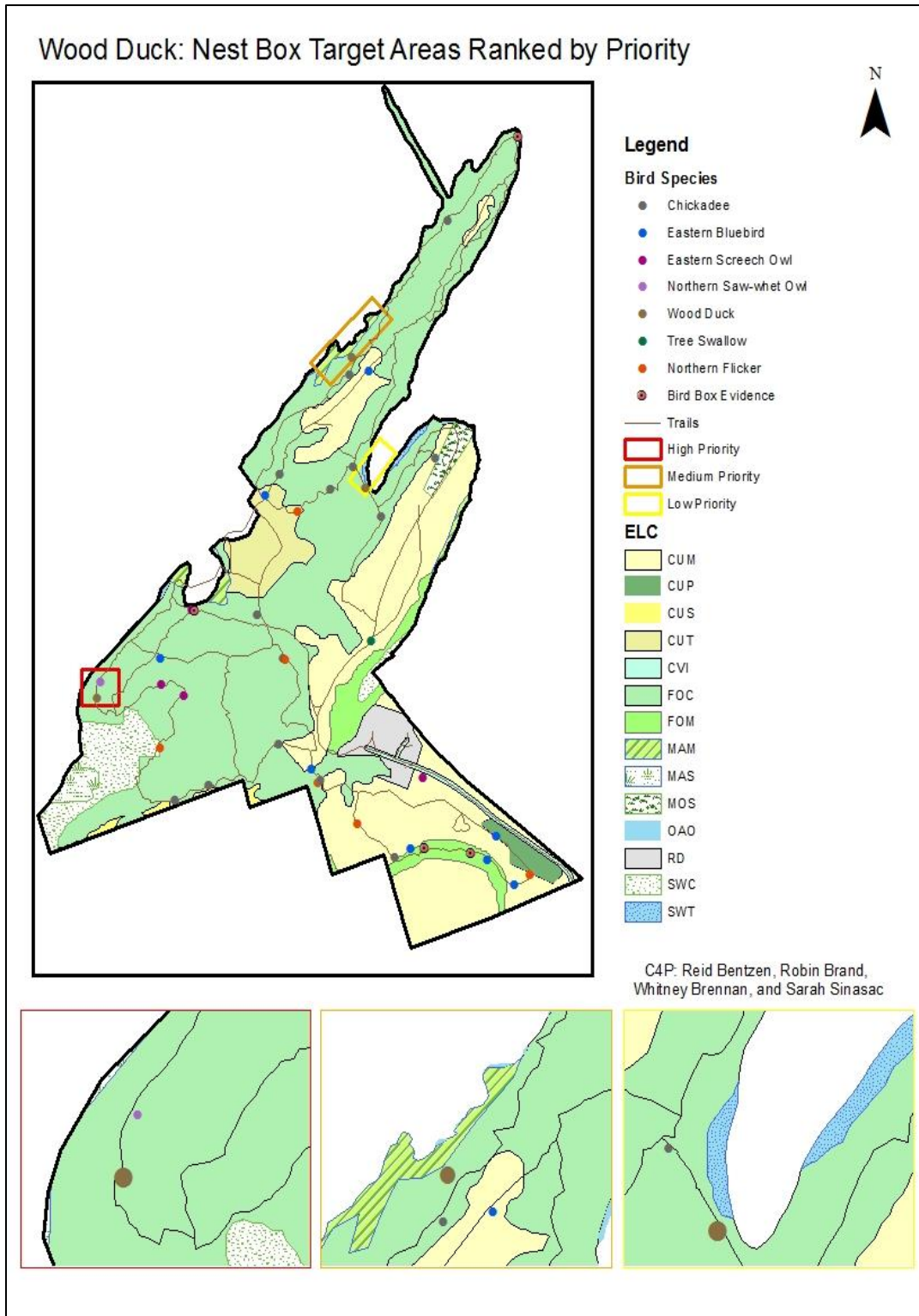

Figure 6: Wood duck established nesting habitats in Ken Reid demonstrating high, medium, and low priority implementation habitats.

Through site evaluations, habitats were selected through the use of the priority scale to determine the maximum habitat value that will provide the greatest amount of benefits to promote reproductive success of wood ducks. The recommended high priority habitat is located along the Trillium Pass trail; the medium priority habitat is located along the Point Trail; and the low proximity habitat is located along the Camp Loop and boardwalk trail.

Table 7: Wood Duck Priority Habitat Descriptions

| Established Habitat | Priority Parameters |
|-------------------------|--|
| High Priority Habitat | <ul style="list-style-type: none"> • Minimal human disturbances due to low amount of human traffic • Optimal foraging habitat and food availability due to proximity of two wetlands • Highly suitable nesting habitat with swamps and wetlands located within surrounding area |
| Medium Priority Habitat | <ul style="list-style-type: none"> • Moderate amount of human disturbances with potentially more competition from other bird species • Optimal foraging area with potentially high food availability • Highly suitable nesting habitat with large wetland located in surrounding area |
| Low Priority Habitat | <ul style="list-style-type: none"> • Human disturbance due to high human activity and close proximity to boardwalk, parking, and picnic areas • Potential foraging habitat with moderate amounts of food availability • Suitable nesting habitats but disturbances could impact nesting possibility |

5.6 Tree Swallow

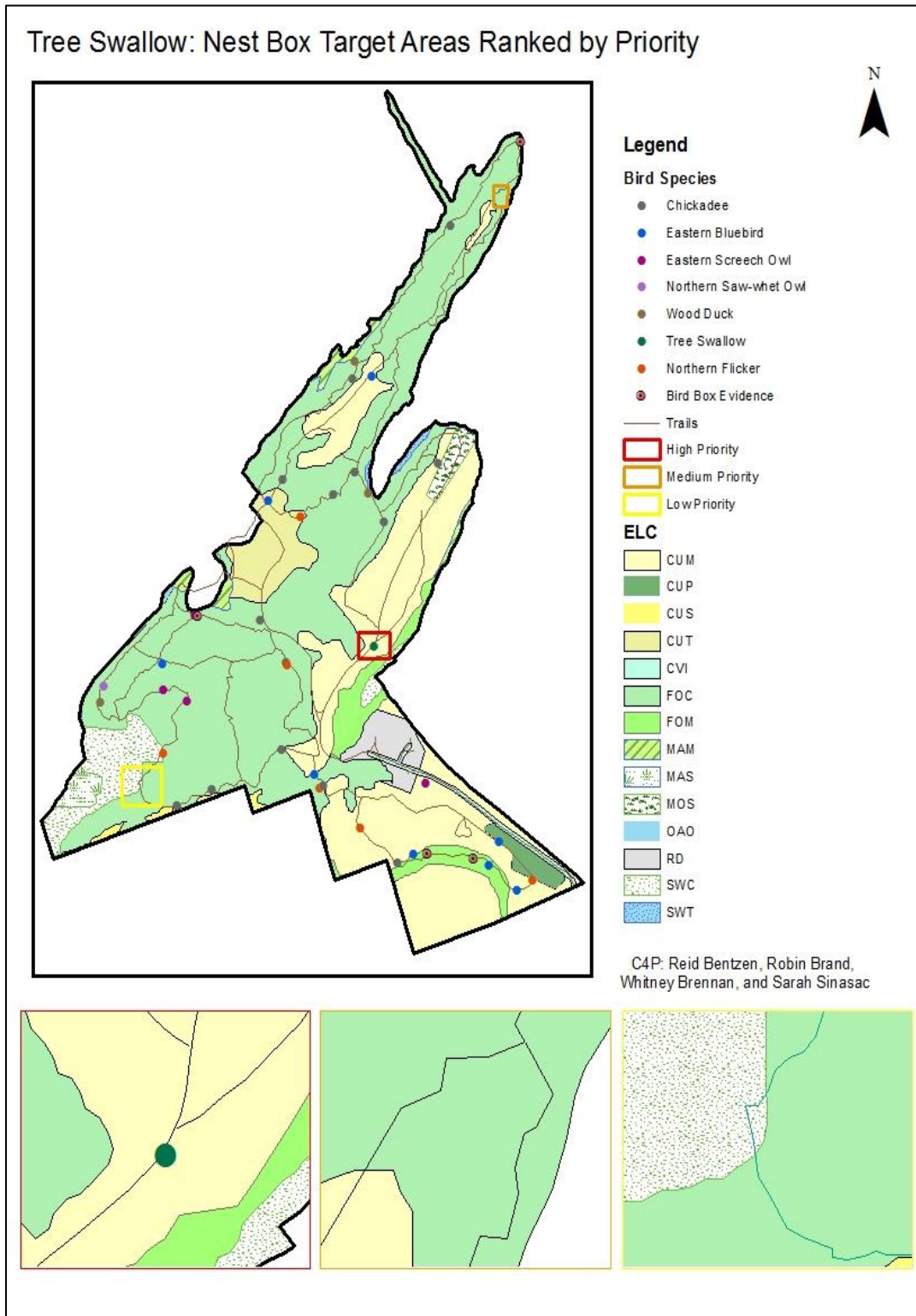

Figure 7: Tree swallow established nesting habitats in Ken Reid demonstrating high, medium, and low priority implementation habitats.

Through site evaluations, habitats were selected through the use of the priority scale to determine the maximum habitat value that will provide the greatest amount of benefits to promote reproductive success of tree swallows. The recommended high priority habitat is located along the Meadow Walk trail; the medium priority habitat is located along the Point Trail; and the low proximity habitat is located along the Woodland Trail.

Table 8: Tree Swallow Priority Habitat Descriptions

| Established Habitat | Priority Parameters |
|-------------------------|---|
| High Priority Habitat | <ul style="list-style-type: none"> • Moderate human disturbances due to proximity of roadway and shelter • High potential foraging habitat due to proximity to water and open field habitats • Suitable nesting habitats due to abundance of edge habitat with aquatic plants and grasses within close proximity |
| Medium Priority Habitat | <ul style="list-style-type: none"> • Lower amount of disturbances due to less utilized trails • High potential for foraging opportunities due to proximity of water • Abundant amount of aquatic plants and grasses to promote nesting materials and optimal nesting site due to forest edge |
| Low Priority Habitat | <ul style="list-style-type: none"> • Moderate human disturbances due to trail activity and higher competition rates with species • Lower potential for foraging habitats due to competition with other cavity nesters • Optimal nesting opportunities due to forest edge and proximity to wetland area |

5.7 Northern Flicker

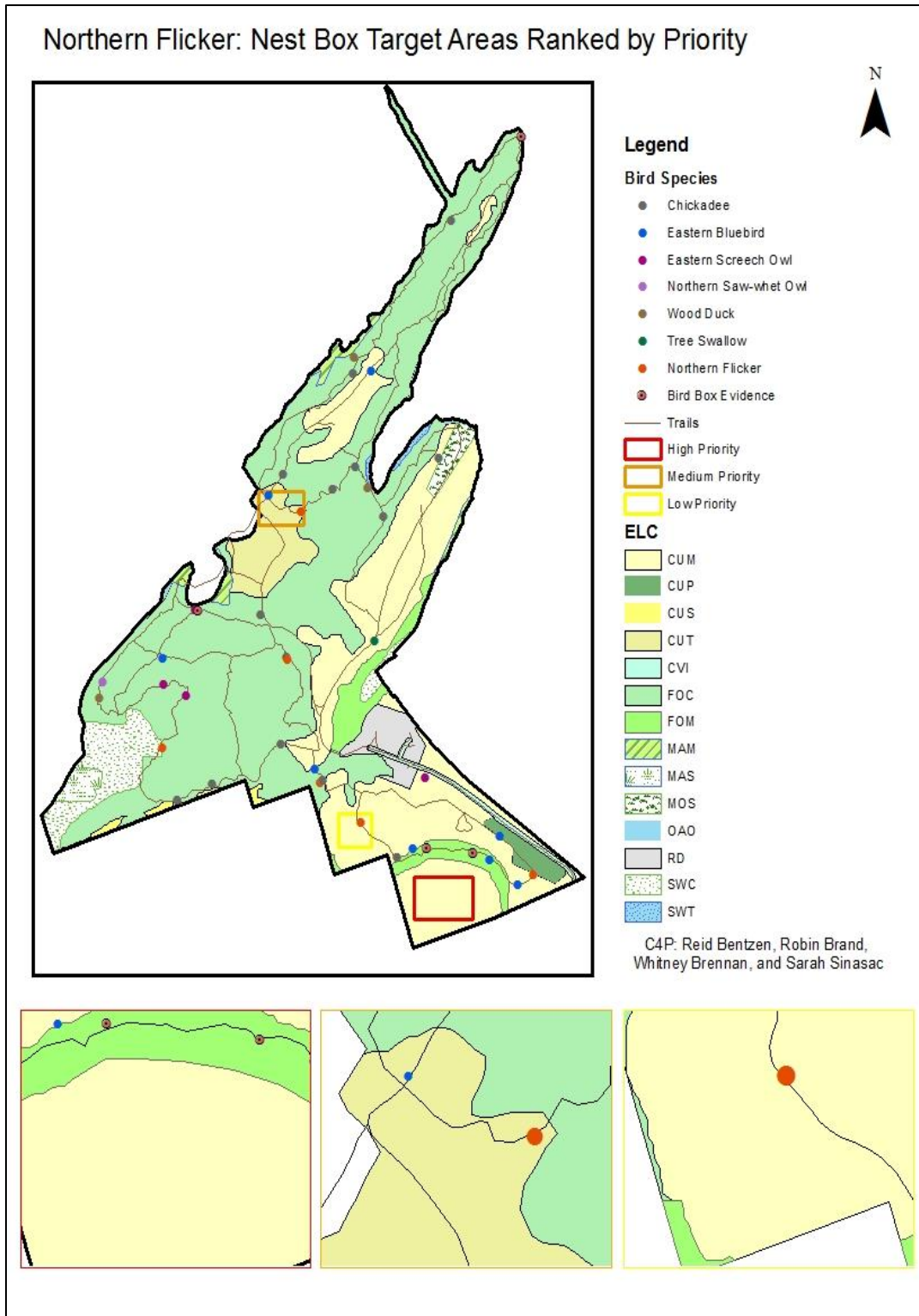

Figure 8: Northern flicker established nesting habitats in Ken Reid demonstrating high, medium, and low priority implementation habitats.

Through site evaluations, habitats were selected through the use of the priority scale to determine the maximum habitat value that will provide the greatest amount of benefits to promote reproductive success of northern flickers. The recommended high priority habitat is located along the Escarpment Trail; the medium priority habitat is located along the Camp Loop trail; and the low proximity habitat is located along the Escarpment Trail.

Table 9: Northern Flicker Priority Habitat Descriptions

| Established Habitat | Priority Parameters |
|-------------------------|---|
| High Priority Habitat | <ul style="list-style-type: none"> • Minimal amount of human disturbances due to located on hilltop • Optimal foraging area due to sumac located within field • Suitable nesting habitat amongst forest edge and fence posts |
| Medium Priority Habitat | <ul style="list-style-type: none"> • Moderate amounts of human disturbances and potential competition with other cavity nesters • High potential foraging opportunities due to open field within proximity to wetland • Optimal nesting habitat due to presence of trembling aspen and edge habitat along cedar forest |
| Low Priority Habitat | <ul style="list-style-type: none"> • Disturbances due to close proximity of dog park and excessive amount of human activities • Potential foraging habitats with some sumac in open field area • Nesting opportunities due to edge habitat along mixed forest |

5.8 Ken Reid Conservation Area Priority Installation Sites

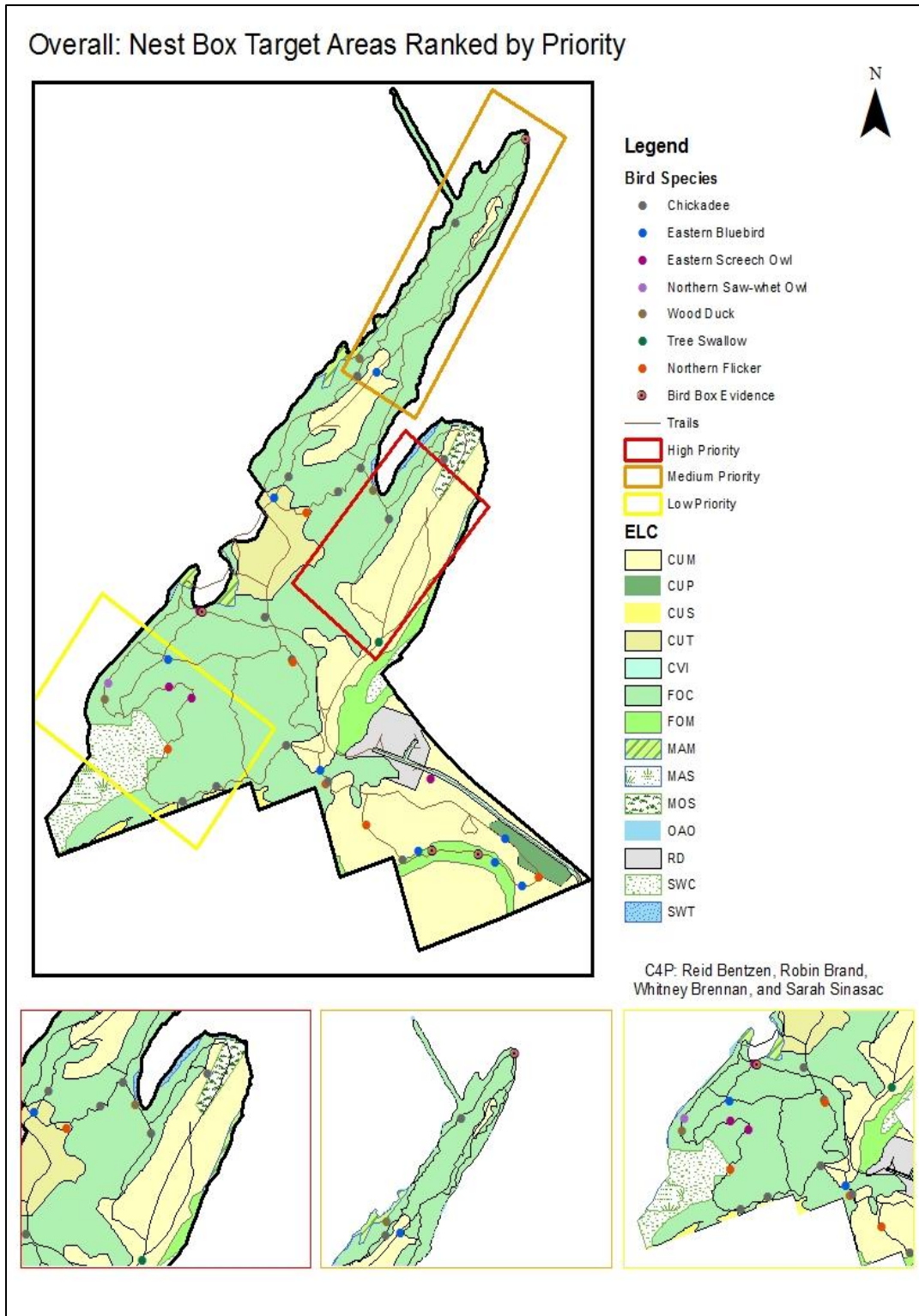

Figure 9: Overall established nesting habitats in Ken Reid demonstrating high, medium, and low priority implementation habitats for all seven species being evaluated.

Through site evaluations, habitats were selected through the use of the priority scale to determine the maximum habitat value that will provide the greatest amount of benefits to promote reproductive success of a variety of species. These habitats were selected by viewing the significance of specie habitats recommended for nest box implementation. The recommended high priority habitat is located along the Meadow Walk and Cedar Forest trails; the medium priority habitat is located along the Point trail; and the low proximity habitat is located along the Woodland and Trillium Pass trails.

Table 10: Ken Reid Conservation Area Priority Habitat Descriptions

| Established Habitat | Priority Parameters |
|-------------------------|---|
| High Priority Habitat | <ul style="list-style-type: none"> • Maximum species promoted and two high priority specie habitats (northern saw-whet owls and tree swallows) within region, along with medium priority habitats (bluebirds) • Some human disturbances within proximity to shelter and playground • Foraging habitats provided for four species within the selected nesting habitat |
| Medium Priority Habitat | <ul style="list-style-type: none"> • Medium (northern saw-whet owls, wood ducks, and tree swallows) to low (eastern bluebirds and black-capped chickadees) priority nesting species habitats are promoted within this selected region to provide moderate reproductive success • Moderate human disturbances • Foraging habitat provided for five species within this selected nesting habitat |
| Low Priority Habitat | <ul style="list-style-type: none"> • Various priority nesting habitats from high (eastern screech owls and wood ducks) to medium (black-capped chickadees) to low (northern saw-whet owls and tree swallows) valued habitats that promote reproductive success for cavity nesters within the selected habitat • Greater human disturbances due to more excessively utilized trails • Foraging habitat provided for five species within this selected nesting habitat • Presence of osprey within proximity to McLarens Marsh that could impact presence of cavity nesters |

5.9 Interpretive Signage Implementation

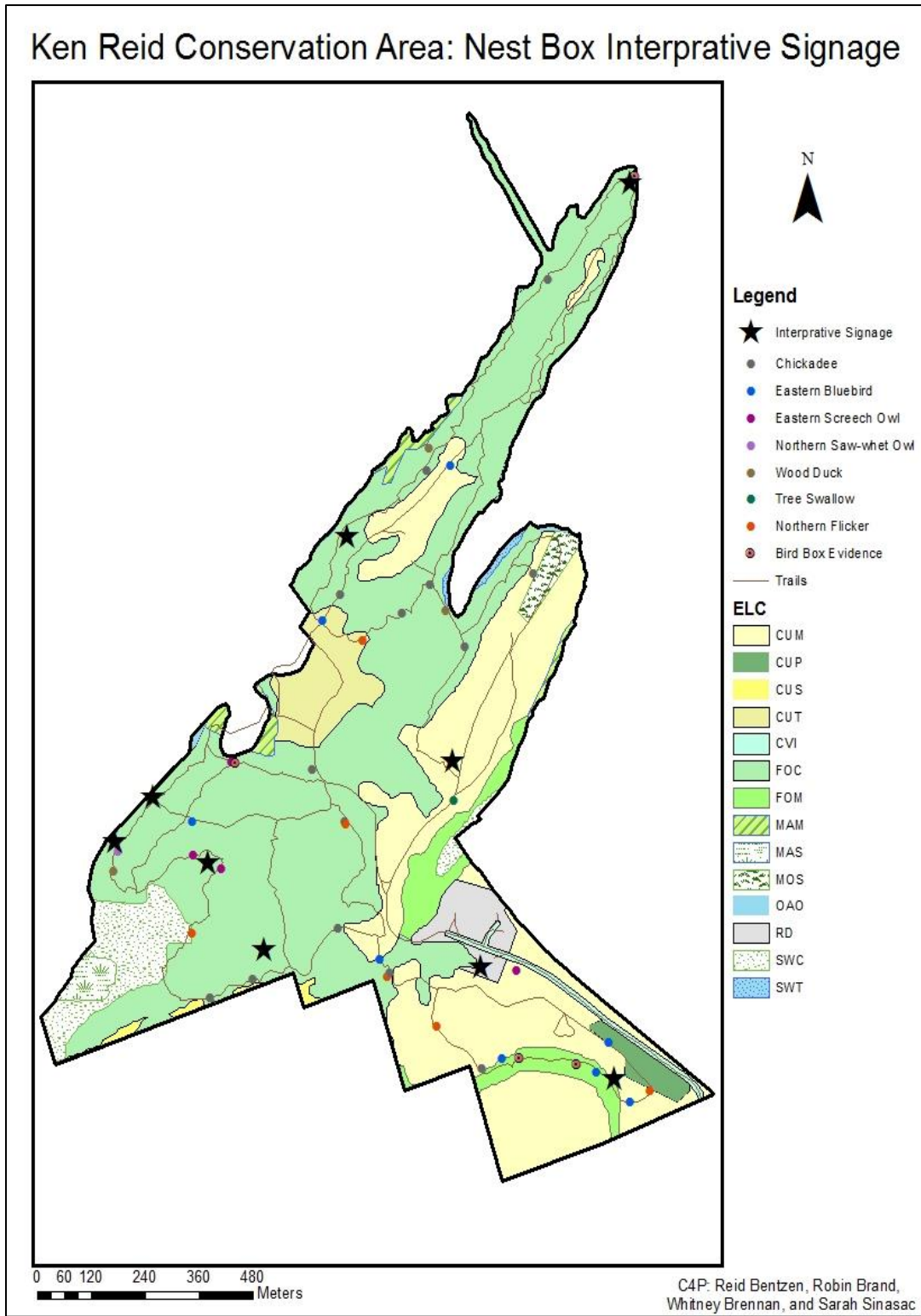

Figure 10: Interpretive signage locations for nest boxes within Ken Reid Conservation Area

The locations for implementation for future interpretive signage was determined through

evaluating various habitat requirements and locations to determine optimal sign location to promote awareness of nest box implementation program in Ken Reid Conservation Area. Interpretive signage can describe cavity-nesting habitats for the seven selected species, along with monitoring practices, material requirements, and specie requirements.

An interpretive signage should be implemented in a high traffic area, such as parking lot, information board, etc. to promote awareness of cavity nesters and nest box locations throughout Ken Reid Conservation Area. A tree swallow interpretive sign can be installed along the Meadow Walk trail to provide specie background information and nesting habitats. An interpretive sign could be installed at the lookout of Point Trail to provide background on cavity nesters and species present within surrounding habitat along the trail. An interpretive sign for northern saw-whet owls could be implemented along the Camp Loop trail to describe habitat requirements and foraging locations. Along the Trillium Pass trail, interpretive signs for wood duck habitat can be implemented, along with installing another sign describing the osprey nest in McLaurens Marsh. It is recommended that an interpretive sign for the eastern screech owl could be installed along the Woodland Trail for habitat requirements for nesting cavities and foraging patterns. At the south trail intersection of Woodland Trail and Rabbit Hollow trail, an interpretive sign could be installed to describe the black-capped chickadee song and features. Another interpretive sign that could be installed in Ken Reid would be along the Escarpment Trail for eastern bluebird foraging habitat descriptions. These are just some of the recommended interpretive signage that can be implemented throughout Ken Reid Conservation Area to promote awareness of cavity nesters and the implementation of nest box.

6.0 Monitoring and Maintenance

Due to the decline in many secondary cavity nesters' populations, the popularity of using nest boxes as replacement habitat has risen (Shutler et al., 2012). However, in order to determine the suitability and occupancy of nest boxes, the boxes must be monitored (Corrigan et al., 2011). Insects or mammal pests can infest nest boxes, or the boxes can become too dirty for inhabitation, or simply become destroyed from use (Lidenmayer et al., 2009). The boxes require monitoring effort through human labour, or through technology such as video cameras (Peirce and Pobprasert, 2007). Nest boxes should be maintained and cleaned annually; this should be done in late winter when there is little to no activity. All nesting material should be discarded in order to prevent the buildup of parasites and mites.

6.1 Monitoring Programs

The Cornell University Lab of Ornithology has created a bird monitoring protocol that is commonly used by most monitoring organizations in North America. The Cornell monitoring protocol would be the best option for Kawartha Region Conservation Authority to use for monitoring of the bird boxes. The protocol is based on the Breeding Biology Research and Monitoring Database Field Protocol, and the data collected using this protocol can be compared with data from other monitoring programs using the same protocol.

The Cornell protocol can be found at the following website: <http://nestwatch.org/learn/how-to-nestwatch/nest-monitoring-protocol/>,
http://nestwatch.org/wp-content/uploads/2013/03/NestWatch_manual_130326.pdf

and a sample monitoring data sheet can be viewed in Figure 20 in Appendix D.

6.2 Disturbances

Bird nest boxes can be disturbed by many factors, which can lead to the boxes being abandoned, and possibly the loss of lives of young birds who are unable to fly or care for themselves. Often bird boxes will be invaded by mammalian or insect pests. European honey bees (*Apis mellifera*) commonly use nest boxes as a nest source and prevent species of birds from using the boxes. Often mice use the nest boxes as nests to raise their young, which also prevents birds from using the boxes. Mammals that enter boxes that are inhabited by birds can destroy the nests, eggs, and even the young nestlings (Czeszczewik et al., 2008). Mammals have been shown to decrease the breeding success of secondary cavity nesting birds (Czeszczewik et al., 2008). Nest boxes can be damaged from winds, rain, or extreme weather events, along with simply aging materials. Humans also provide disturbance effects for nest boxes. Certain species are more tolerant to human disturbance than others, and birds will likely select nests that are not close to human disturbance sources (Ramacha and Delgado, 2009). Trails have an impact on nest selection, but buildings have a much larger negative impact on breeding rates and nest box use (Ramacha and Delgado, 2009). Therefore the nest boxes can be placed near trails, but would likely have a higher occupation rate further away from the trails, and away from high intensity human disturbance. Birds have been shown to prefer areas that are not near areas with high dog use (ie. off-leash park), meaning that the nest boxes should be placed far away from the dog park when possible (University of Washington, 2014).

7.0 Funding

The Kawartha Region Conservation Authority is a registered charity, and is therefore eligible for monetary grants and donations from many sources. This section will provide a list of potential funders within the region, and potential volunteer sources. A rank number is provided for all the funding sources that represents how likely the source is to donate to Kawartha Region Conservation Authority. The lower rank numbers are more likely to donate, and the higher rank numbers are less likely. A description of each funding source is provided after the table.

Table 11: Potential Funding Sources

| Rank | Funding Source | Funding Type | Website |
|------|------------------------------|--------------------------|---|
| 6 | RONA | Materials and Monetary | http://www.rona.ca/corporate/partners-and-sponsors |
| 1 | Fleming College Frost Campus | Materials and Volunteers | http://flemingcollege.ca/campus/frost-campus |
| 3 | Evergreen Green Grants | Monetary/Materials | http://www.evergreen.c |

| | | | |
|----|-------------------------------------|------------|---|
| | | | a/en/funding/grants-available/green-grants/ |
| 2 | Lindsay Legacy CHEST Fund | Monetary | https://www.city.kawartha.ca/city-hall/agendas-and-minutes/lindsay-legacy-chest-fund |
| 7 | Ontario Trillium Foundation | Monetary | http://otf.ca/en/applyForGrant/community_grants.asp |
| 4 | TD Friends of The Environment | Monetary | https://fef.td.com/funding/ |
| 10 | The International Osprey Foundation | Monetary | http://www.ospreys.com |
| 9 | Bird Studies Canada | Volunteers | http://www.bsc-eoc.org |
| 5 | Kawartha Field Naturalists | Volunteers | http://www.kawarthafieldnaturalists.org/index.php |
| 8 | Nature Canada | Volunteers | http://www.naturecanada.ca/bird_cons.asp |

7.1 Material Funding

RONA - <http://www.rona.ca/corporate/partners-and-sponsors>

“RONA’s sponsorships and community initiatives aim to instil sportsmanship, social responsibility, the incentive to renovate as well as perseverance” (RONA, 2014).

RONA provides sponsorships in the form of money or materials every year to worthy organizations and projects. RONA is interested in projects that promote social responsibility, and environmental conservation. For example, RONA is currently funding a project called Together With Totem, which aims to plant one million trees in Northern Alberta to offset carbon dioxide emissions. RONA tries to sell products that do not have a large ecological footprint, and has a line of eco-responsible products. RONA would be an excellent starting point on the search for material donations.

Sir Sandford Fleming College Frost Campus - <http://flemingcollege.ca/campus/frost-campus>

The Frost Campus of Fleming College is very concerned with sustainable use of resources and

sustainable living, and often has student volunteers that are willing to help with local projects. The fish hatchery on campus uses PVC pipe, and often has left over material. Fleming College would likely donate remaining material to Kawartha Region Conservation Authority, since the two organizations have partnered in the past.

7.2 Monetary Funding

Evergreen Green Grants - <http://www.evergreen.ca/en/funding/grants-available/green-grants/>

Evergreen works with Walmart to fund projects all over the country. There are many types of projects that Evergreen funds including Wildlife Habitat Restoration projects, which is the heading that the Kawartha Region Conservation Authority Bird Box project would fall under. The organization will provide building materials and money for expenses. Evergreen provides grants for organizations all across Canada. In 2013, Evergreen provided aid for 14 programs throughout Ontario alone. Past successful applicants included Adopt-a-Tree in Toronto, the Eastview International Garden Project in Toronto, the Riverwood Slope Restoration in Mississauga, the Hamilton Naturalist's Club Community Stewardship program in Hamilton, and many others. Evergreen funds small local projects and promotes environmental education. Applications for Evergreen grants are due in February every year. Many of the funded projects include community involvement and education, however some are simply restoration projects.

Lindsay Legacy CHEST Fund - <https://www.city.kawarthalakes.on.ca/city-hall/agendas-and-minutes/lindsay-legacy-chest-fund>

The CHEST Fund has donated \$5,000 dollars to past projects at Fleming, and therefore would be a likely source of funding for the Kawartha Region Conservation Authority Bird Box project. The program funds non-profit organizations that attempt to better the Lindsay community through health, arts, leisure, education and the environment.

Ontario Trillium Foundation - http://otf.ca/en/applyForaGrant/community_grants.asp

The Ontario Trillium Foundation provides community grants of up to \$75,000 per year. Community grants focus on projects that have a large impact on the local area. The grant deadlines are March 1, July 1 and November 1, each year. Grants are usually provided to programs that have a local impact on the community. Most of the grants from Ontario Trillium grants are for over \$20,000 for community based learning projects and staff salaries. However, some past grants have been to repair and update equipment (Lake Huron Fishery Club needed new trout hatchery equipment), so there could be a possibility of Ontario Trillium Foundation granting Kawartha Region Conservation Authority some funds for the bird box project.

TD Friends of the Environment - <https://fef.td.com/funding/>

TD funds many projects including projects with themes such as habitat restoration and endangered species/wildlife protection, which would include nest boxes used for wildlife protection. TD funds over 1000 projects annually, and lists all their funding recipients on their website. Some funded projects are nearby, such as Camp Kawartha, and some are conservation authorities, such as Credit Valley

Conservation. Registered charities are eligible for funding, and funding can be applied for at 4 different times during the year.

The International Osprey Foundation - <http://www.ospreys.com>

This organization aims to protect and aid in the recovery of the osprey. They issue grants to researchers whose studies involve environmental concerns. Typically, awards are issued to raptor research departments and universities. However, money has been issued in the past for the repair of an osprey flight cage. Therefore, if some of the money was used for osprey nest tower rehabilitation there could be a chance of receiving funding from this corporation. However, it is not likely that they would give money simply for bird box creation and implementation.

7.3 Volunteer Sources

Bird Studies Canada - <http://www.bsc-eoc.org>

Bird Studies Canada wishes to advance understanding, appreciation and conservation of Canada's wild birds and their habitats. It is a not-for-profit organization, however, it employs volunteers to help with projects. Bird Studies Canada encourages people to volunteer with specific programs that it supports. Most of the programs in Ontario are bird surveys, and bird monitoring programs. Kawartha Region Conservation Authority could potentially become one of the listed organizations that asks volunteers to help with monitoring programs. There could be a possibility of having Bird Studies Canada advertise for Kawartha Region Conservation Authority in order to bring in volunteers.

Kawartha Field Naturalists - <http://www.kawarthafieldnaturalists.org/index.php>

Kawartha Field Naturalists is a not-for profit group, with a large volunteer base. They have a concerned citizens sections, where citizens can sign up to help with local projects. This could be a potential source for materials and volunteers. The Kawartha Field Naturalists organization is part of Ontario Nature, a large base group for concerned naturalists. Members of the group are usually from Lindsay and surrounding areas. The Kawartha Field Naturalists are currently active at the Altberg Nature Reserve, where they monitor birds and salamanders, and also support the Bill Watts Bluebird trail. Bill Watts was a member of the Kawartha Field Naturalists, and built bluebird nest boxes and placed them in suitable habitat areas along a trail in Fenelon Falls. The trail and boxes are maintained now by members of the Kawartha Field Naturalists.

Nature Canada

Nature Canada's mission is to protect and conserve wildlife and habitats in Canada. It is also a not-for profit organization, however, it may be a volunteer source. Nature Canada works with Bird Studies Canada to monitor important bird habitats across Canada. Nature Canada has a volunteer network and sets up volunteers to help with bird monitoring. Nature Canada works to make sure local communities are aware of conservation methods for birds and has specific volunteers in every regions to promote habitat conservation.

8.0 References

Corrigan, R.M., Scrimgeour, G.J., and Paszkowski, C. (2011). Nest boxes facilitate local-scale conservation of Common Goldeye (*Bucephala clangula*) and Bufflehead (*Bucephala albeola*) in Alberta, Canada. *Avian Conservation and Ecology* 6(1), 1-18.

Czeszczewik, D., Walankiewicz, W., & Stanska, M. (2008). Small mammals in nests of cavity-nesting birds: Why should ornithologists study rodents?. *Canadian Journal of Zoology*, 86(4), 286-293.

James, R. D. (1984). Habitat management guidelines for cavity-nesting birds in Ontario. Ontario Ministry of Natural Resources.

Lidenmayer, D.B., Welsh, A., Donnelly, C., Crane, M., Michael, D., Macgregor, C., McBurney, L., Montague-Drake, R., and Gibbons, P. (2009). Are nest boxes a viable alternative source of cavities for hollow-dependent animals? Long-term monitoring of nest box occupancy, pest use and attrition. *Biological Conservation* 142(1), 33-42.

Peirce, A.J., and Pobprasert, K. (2007). A portable system for continuous monitoring of bird nests using digital video recorders. *J. Field Ornithol.* 78(3): 322–328.

Shutler, D., Hussell, D.J.T., Norris, D.R., Winkler, D.W., Robertson, R.J., Bonier, F., Rendell, W.B., Belisle, M., Clark, R.G., Dawson, R.D., Wheelwright, N.T., Lombardo, M.P., Thorpe, P.A., Truan, M.A., Walsh, R., Leonard, M.L., Horn, A.G., Vleck, C.M., Vleck, D., Rose, A.P., Whittingham, L.A., Dunn, P.O., Hobson, K.A., and Stanback, M.T. (2012). Spatiotemporal patterns in nest box occupancy by tree swallows across North America. *Avian Conservation and Ecology* 7(1), 3-12.

University of Washington. (2014). Conservation: Do dogs keep birds away from urban parks? Retrieved on February 8th, 2014, from: <http://conservationmagazine.org/2013/11/dogs-keep-birds-away-urban-parks/>.

9.0 Appendix

9.1 Appendix A: Nest Box Plans

Black-capped Chickadee

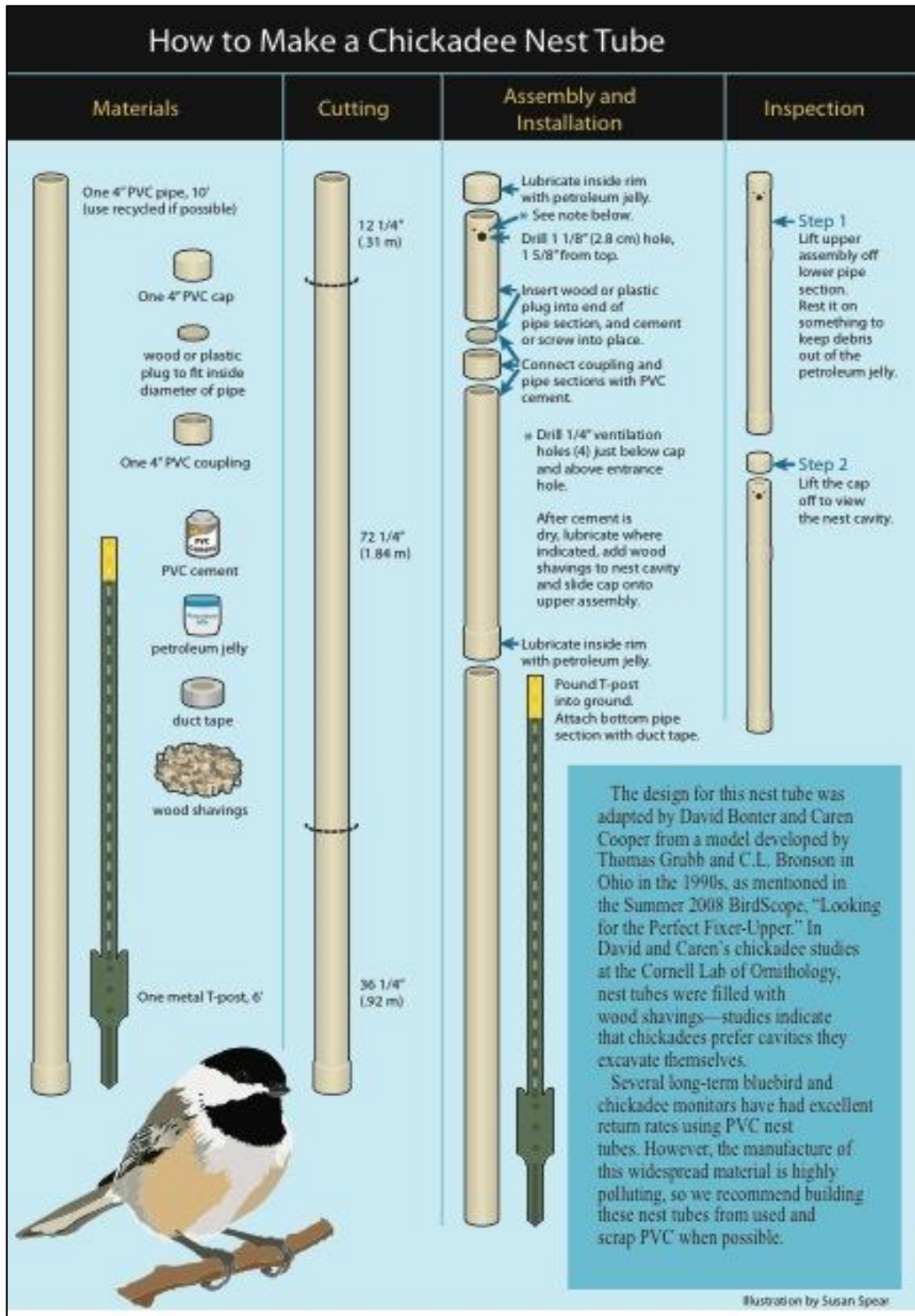

Figure 11: Black-capped chickadee PVC nesting tube

Eastern Bluebird & Tree Swallow

Nest Box Plan for:

Tree Swallow Eastern Bluebird Great Crested Flycatcher

ASSEMBLY INSTRUCTIONS:

The nesting box pictured has been carefully designed to meet bluebirds requirements, to last for years, and to provide for easy mounting and easy access for observation and cleaning. It cannot be entered by starlings and, if properly located, sparrow interference will be somewhat minimized.

PAINTING

Nesting boxes made of cedar, cypress, redwood or exterior grade plywood need not be painted. Boxes made of other woods will last longer if painted with exterior type latex paint. Use light colors only to prevent overheating. Paint the outside of the box. Do not use paints that contain lead or toxic wood preservatives such as pentachlorophenol. Exterior plywood is recommended for the top board since it will not warp.

MOUNTING

By using the small holes shown in the top and bottom extensions of the backboard, the box may be nailed or screwed to the top or side of a wooden post, or it may be bolted or wired to the top or side of a metal post. A smooth metal post such as a galvanized pipe is preferred to a wooden post since it offers better protection against climbing predators, particularly if the post is coated with soft grease while the bluebirds are occupying the box. A 1/2 or 3/4 inch galvanized pipe threaded at one end can be neatly and firmly attached to the bottom of the box by means of pipe flange which may be obtained at any hardware store. When mounting wires (see plan) are used to mount the box on the side of a metal post the two ends of the upper wire are inserted through the 1/8" holes near the top of the backboard. This must be done with the side wide open. If the box is mounted on the side of a wooden post or tree trunk a round-headed screw may be used in the 3/16" hole in the backboard. A long-handled screw driver is inserted through the entrance hole of the box. A metal washer should be used on the screw.

RACCOONS

A raccoon guard made of a small board 1 1/2" thick with a 1 1/2" hole helps to control raccoons and other large predators. This guard is attached firmly to the front of the box so that the hole coincides exactly with the entrance hole in the box. Extra deep nesting boxes are also helpful.

MAINTENANCE

Bluebirds nests should be removed from the boxes as soon as the young have left since this will increase the chances of second or third broods being raised in the same boxes. The boxes should be inspected, cleaned, and repaired if necessary in late winter each year, making sure that the drain holes in the floors are open.

Plan for Side-opening Nesting Box With 5" X 5" Floor

Dimensions shown are for boards 3/4" thick. Use 1 3/4" galvanized siding nails or aluminum nails. Pivot nails must be located exactly opposite each other as shown for proper opening of side board. Cut top edges of front and back boards at slight angle to fit flush with top board. Cut 3/8" off each corner of bottom board as shown. Insert bottom board so that the grain of the wood runs from the front to the rear of box.

Nest box plans reprinted with permission from the North American Bluebird Society, Inc.

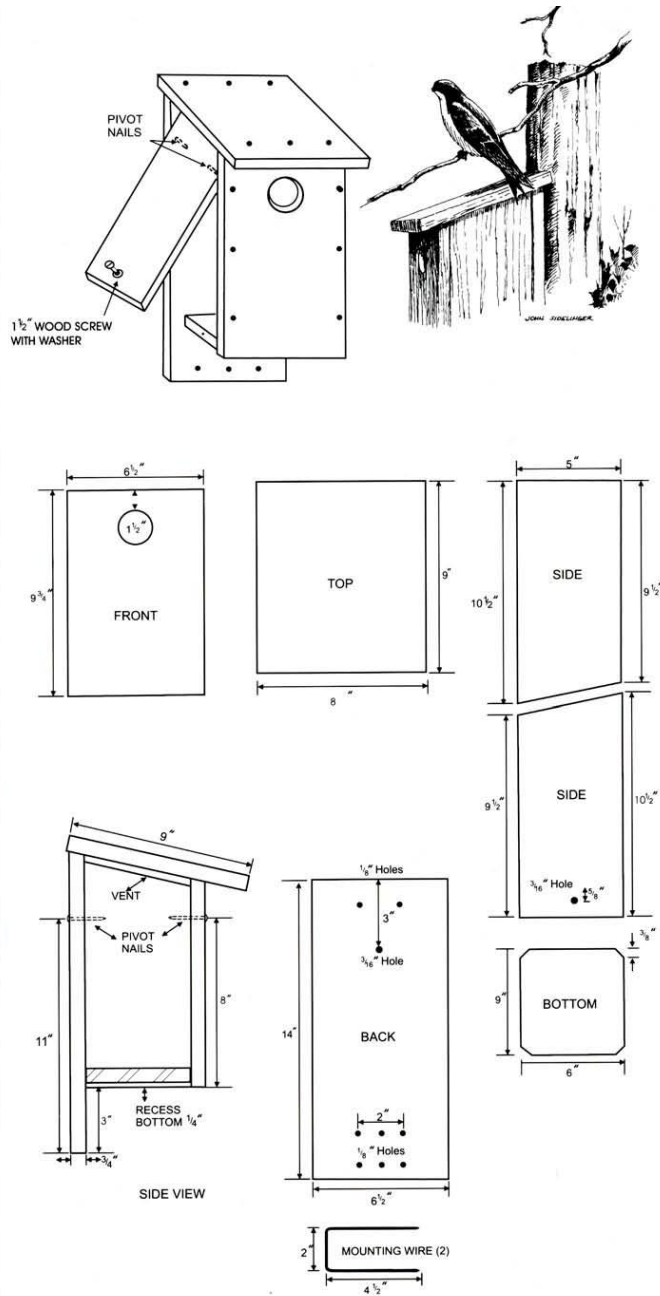

Published with permission from *Woodcrafting for Wildlife*

Figure 12: Eastern bluebird and tree swallow wood nest box plan

Eastern Screech Owl & Northern Saw-whet Owl

American Kestrel Screech-Owl Northern Saw-whet Owl

SUPPLIES NEEDED:

Use raw pine or cedar. Do not paint or treat with a wood preservative.

An outside perch is not necessary and may attract other species to the box.

Use 1-5/8" galvanized deck screws for the box.

You can place a perch inside (using cutout from entrance) about three inches below entrance hole.

Place 2" of coarse wood shavings (not sawdust) in bottom of box, each year before nesting season.



SIDE VIEW WITH DOOR

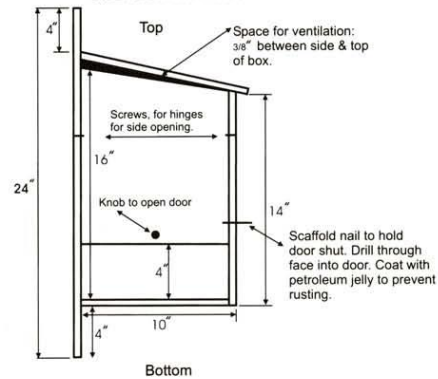

SIDE VIEW OTHER SIDE OF BOX

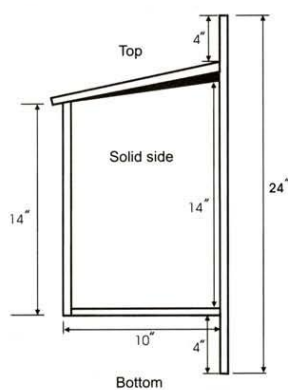

FRONT VIEW OF BOX

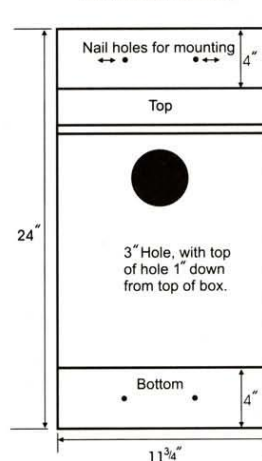

BOTTOM OF BOX

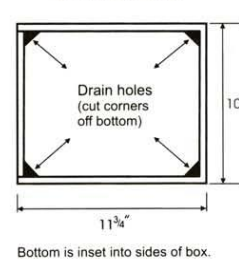

Printed with permission from *Woodcrafting for Wildlife*

Figure 13: Eastern screech owl and northern saw-whet owl nest box plan

Wood Duck

Box Plans for: Common Merganser Hooded Merganser Wood Duck

ENTRANCE HOLES

Common Merganser
min. 5" diameter round

Wood Duck & Hooded Merganser
3" high & 4" wide oval

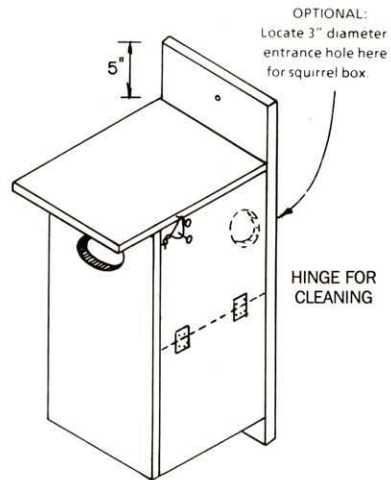
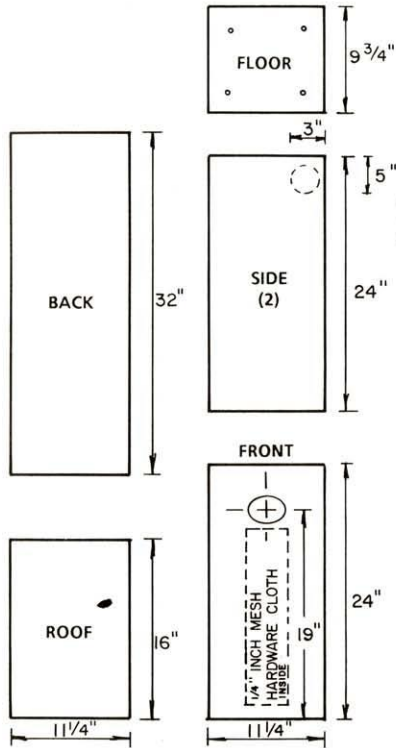

FOR WOOD DUCK HOUSE -
Place 3-4" Chainsaw Wood Chips in
bottom of box.

LUMBER:
ONE 1" X 12" X 12'0"

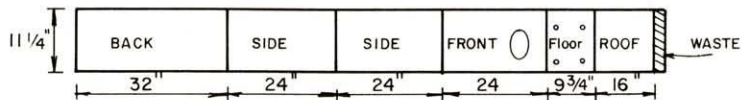

Published with permission from *Woodcrafting for Wildlife*

Figure 14: Wood duck nest box plan

Northern Flicker

Nest Box Plan for Northern Flicker

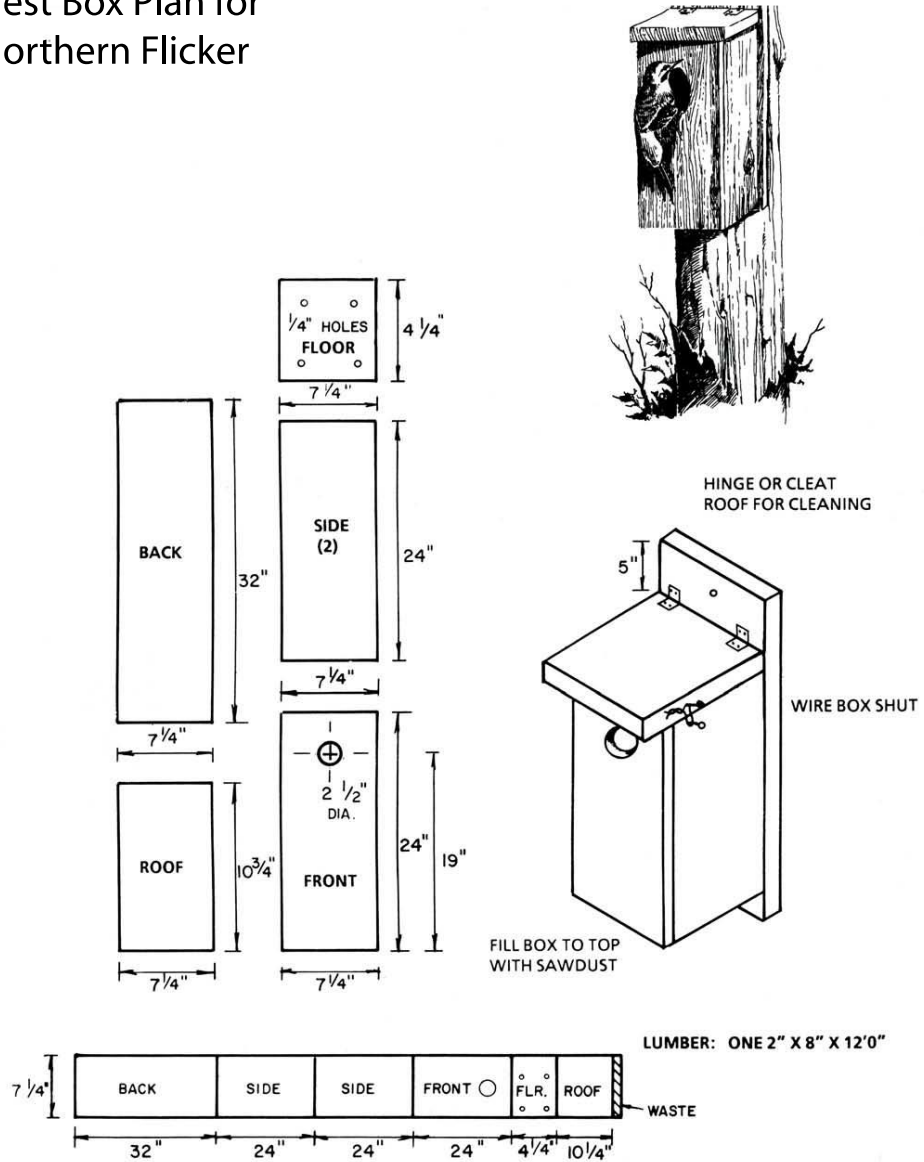

Published with permission from *Woodcrafting for Wildlife*

Figure 15: Northern flicker nest box plan

9.2 Appendix B: Predator Guards

Conical Predator Guard

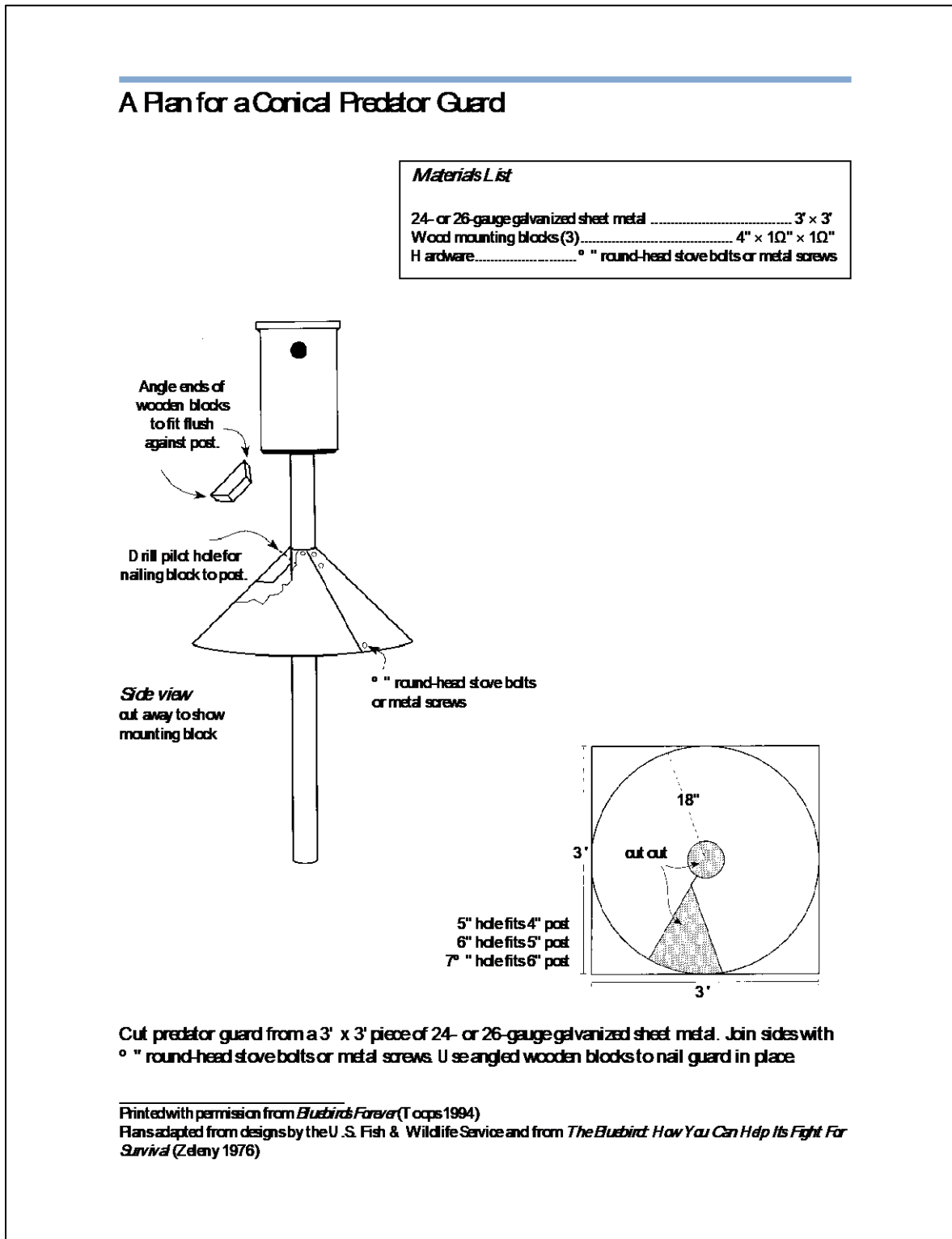
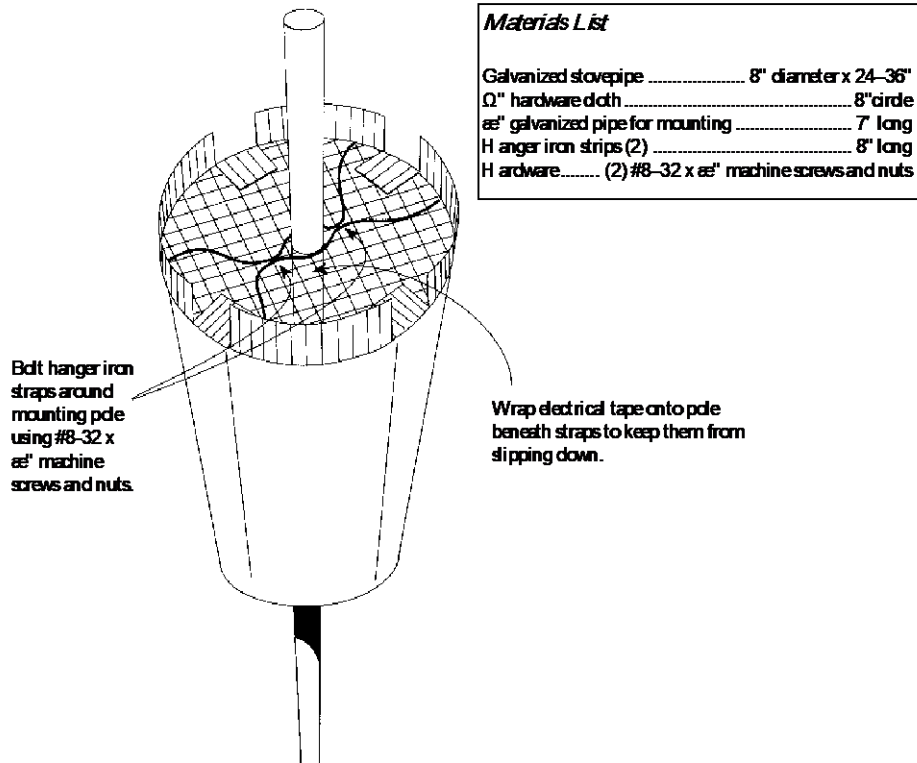

Figure 16: Conical predator guard construction and installation plan

Stovepipe Predator Guard

A Plan for a Stovepipe Predator Baffle



Using tin snips, shape hardware cloth into a circle. Make a small cut in the center so it will slip over the mounting pole. Bend the edges of the hardware cloth down and slide it snugly into the stovepipe. Cut four tabs on the top end of the stovepipe. Bend them inward, over the hardware cloth.

Bolt the hanger iron straps together in the center, around the mounting pole. Bend the free ends outward to support the hardware cloth. A few wraps of electrical tape below the strap attachment will keep it from slipping down the pole. Slide the stovepipe assembly over the top of the mounting pole, resting it on the hanger straps. Attach the nest box onto the pole, with the bottom of the box about six inches above the top of the baffle. Smear a heavy-duty wax (for example, carnauba wax) on the pole beneath the baffle to repel ants.

Printed with permission from *Bluebirds Forever* (Toops 1994)

Plan design by Ron Kingston, *Sialia* 13(2):56-57

Art reference from "Enjoying Bluebirds More" in *Bird Watcher's Digest* (1-800-879-2473)

Figure 17: Stovepipe predator guard construction and implementation plan

Noel Predator Guard

A Plan for a Noel Predator Guard

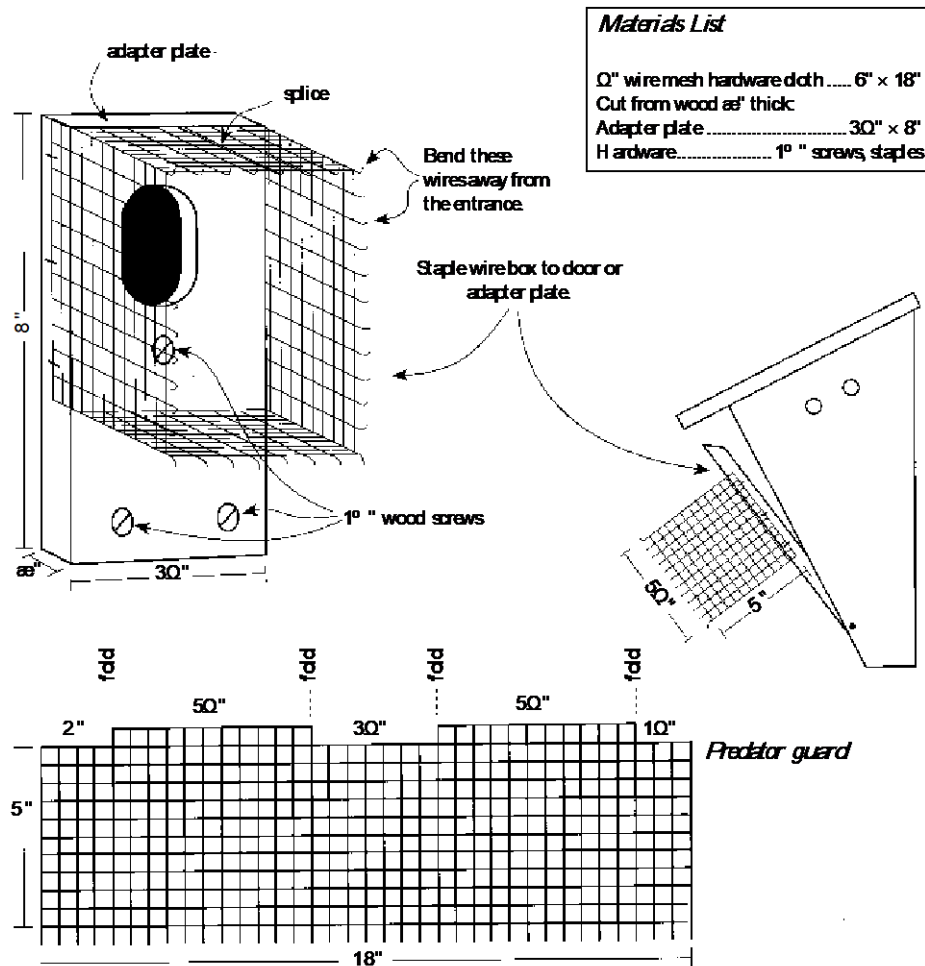

The wire mesh guard may be attached directly to the box front by stapling along the edges of the door. (Edges may need to be planed to allow for the thickness of the wire.) To make the guard more versatile, staple the wire mesh to an adapter plate with an entrance hole that matches your nest boxes. The adapter can be screwed onto box fronts as needed. To further impede predators, you can string a piece of wire across the guard. Connect the wire to each side of the guard and position it across the entrance hole and about three inches away from the hole. Noel guards are most effective when installed after the first egg is laid.

Printed with permission from *Bluebirds Forever* (Troops 1994)
 Original design by Jim Noel
 Adapted by John Thompson

Figure 18: Noel predator guard construction and implementation plan

9.3 Appendix C: Ken Reid Conservation Area Trail Map

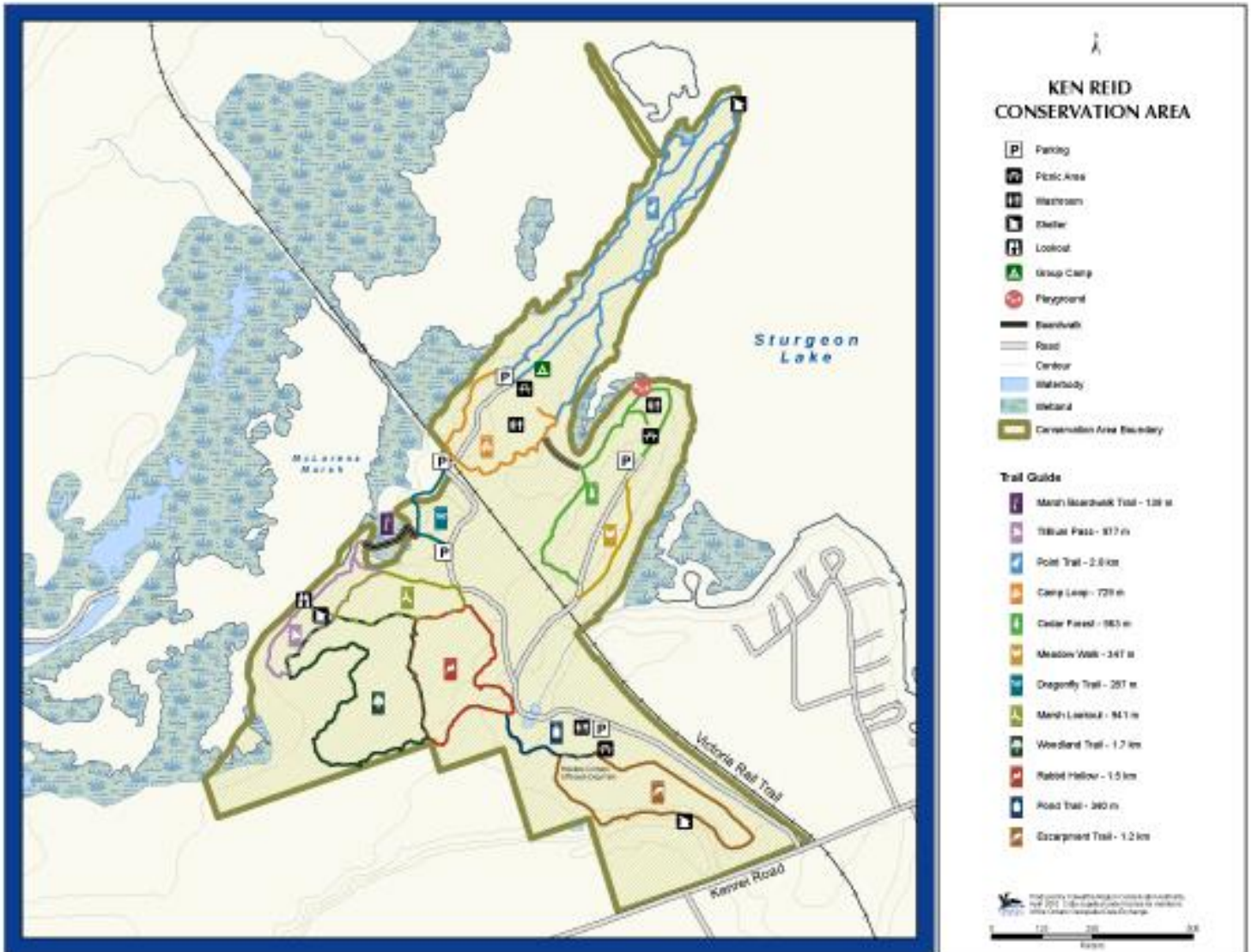



Figure 19: Trail map for Ken Reid Conservation Area

9.4 Appendix D: Cornell Nest Watch Monitoring Protocol



Nest check data sheet

Use this form to describe your nest site and to record data from each visit. Use a separate sheet for each nest monitored and each new nesting attempt. See back side for explanations of codes and fields. When finished, please enter completed sheets online at: www.NestWatch.org.

Year 2018 Species Tree Swallow

| 1. NEST SITE LOCATION | | | | | | 2. SITE DESCRIPTION <small>(See key on back)</small> | | | | | | | | | |
|---|---------------------------|--------------|--------------|------------|------------|---|--------------|----------------------|----------------|-------------------------|------------|---------------------|-------------|---------------------|--|
| Nest Site Name <u>Box 1A</u> | | | | | | Nest is located (circle one): (IN) ON UNDER | | | | | | | | | |
| Nearest address <u>123 Hickory Street</u> <u>ITHACA, NY 14850</u> -OR- Latitude (decimal degrees; ex. 47.67932) N _____ Longitude (decimal degrees; ex. -76.45448) W - _____ | | | | | | Nesting substrate <u>Nest box</u> Cavity orientation (N,E,S,W) <u>NE</u> Cavity opening width (in. or cm.) <u>1.5 in.</u> Habitat within 1 am length <u>Human Modified</u> Human modified description <u>Yard</u> Habitat within 1 football field length <u>Human Modified</u> Human modified description <u>Residential Area</u> Elevation (ft. or m.) <u>550 ft.</u> Height above ground (ft. or m.) <u>4.8 ft.</u> | | | | | | | | | |
| 3. BREEDING DATA <small>If eggs or young are present but not countable, enter "u" for unknown.</small> | | | | | | | | | | | | | | | |
| Visit # | DATE & TIME | | HOST SPECIES | | | STATUS & ACTIVITY CODES | | | | COWBIRD ACTIVITY | | | MORE INFO | | |
| | Month / Day (1-12 / 1-31) | Time (am/pm) | Egg | Live Young | Dead Young | Nest Status | Adult Status | Young Status | Mgmt. Activity | Egg | Live Young | Dead Young | Obs. In/Out | Notes Below | |
| Ex. | 5 / 6 | 2pm | 1 | 0 | 0 | EW | AA | NA | NA | 0 | 0 | 0 | BB | X | |
| 1 | 5 / 8 | 2pm | 2 | 0 | 0 | CH | VA | - | NA | 0 | 0 | 0 | MS | | |
| 2 | 5 / 12 | 3pm | 5 | 0 | 0 | CH | AA | - | NA | 0 | 0 | 0 | MS | | |
| 3 | 5 / 17 | 4pm | 5 | 0 | 0 | CH | VA | - | NA | 0 | 0 | 0 | MS | | |
| 4 | 5 / 22 | 1pm | 4 | 4 | 0 | CH | EA | - | NA | 0 | 0 | 0 | MS | X | |
| 5 | 5 / 26 | 4pm | 1 | 4 | 0 | CH | VA | HY | NA | 0 | 0 | 0 | MS | | |
| 6 | 6 / 1 | 5pm | 1 | 4 | 0 | CH | VA | DY | NA | 0 | 0 | 0 | MS | | |
| 7 | 6 / 8 | 4pm | 4 | 4 | 0 | CH | FA | FY | NA | 0 | 0 | 0 | MS | X | |
| 8 | 6 / 6 | 2pm | 1 | 0 | 0 | CH | VA | YY | NA | 0 | 0 | 0 | MS | | |
| 9 | 6 / 20 | 6pm | 1 | 0 | 0 | CH | NO | NO | EM | 0 | 0 | 0 | MS | | |
| 10 | / | | | | | | | | | | | | | | |
| 4. NESTING ATTEMPT SUMMARY <small>*Fill in information for HOST SPECIES below after the nesting attempt is complete.</small> | | | | | | | | | | | | | | | |
| IMPORTANT DATES: | | | | | | HOST SPECIES TOTALS: | | | | | | | | | |
| First Egg Date <u>5/7/18</u> | | | | | | Visits to nest <u>9</u> | | Clutch Size <u>5</u> | | Unhatched Eggs <u>1</u> | | Live Young <u>4</u> | | Fledglings <u>4</u> | |
| Hatch Date <u>5/25/18</u> | | | | | | | | | | | | | | | |
| Fledge Date <u>unknown</u> | | | | | | | | | | | | | | | |
| NEST FATE: <u>May 22 - I could not see because the female remained on the nest during my nest check.</u> | | | | | | | | | | | | | | | |
| COMMENTS: <u>JUNIE B - Checked box from a distance, but could tell young still in the nest.</u> | | | | | | | | | | | | | | | |



NestWatch Manual • 15

Figure 20: Sample monitoring data sheet provided by Cornell Nest Watch

9.5 Appendix E: Project Plan

| | |
|---|--|
| Project Title | Kawartha Region Conservation Authority Bird Box Project |
| Project Management Team (ie. Student Team) | Reid Bentzen, Robin Brand, Whitney Brennan, and Sarah Sinasac. Students attending Ecosystem Management Technology Program at Sir Sandford Fleming College |
| Faculty | Sara Kelly, Credit for Product Instructor at Sir Sandford Fleming College |
| Project Sponsor(s) | Rod Stavinga, Watershed Resources Technician, Kawartha Region Conservation Authority |
| Purpose | <p>The purpose of the project is to further implement the construction, installation, and monitoring program for bird nesting boxes in Ken Reid Conservation Area in the Kawartha Lake region. This project will contribute to providing suitable habitats for bird species relying on cavities for their reproductive success.</p> <p>Kawartha Region Conservation Authority Mission Statement and Mandate To provide leadership in conservation by focusing on promoting healthy landscapes through stewardship and science. Outstanding water quality and quantity management, supported by healthy landscapes through planning, stewardship, and science.</p> <p>This project aims to increase habitat health by providing habitats for cavity nesting birds, and therefore relates to the Conservation Authority's mandate of increasing ecosystem health in order to maintain or increase water quality.</p> |
| Issue | The specific issue being addressed is the lack of mature trees within Ken Reid for cavity nesters to create nests in. This issue could be potentially resolved by providing cavity nesters with suitable bird boxes in preferential habitat areas. |
| Deliverables | <ul style="list-style-type: none"> - Map of the habitat types at Ken Reid Conservation Area – final product will be handed over on a jump drive provided by the mentor in .jpg format and ArcMap format, along with a hard copy. |

| | |
|------------------------------------|---|
| | <ul style="list-style-type: none"> - Four literature reviews on topics chosen by the mentor, to be completed by week 6 and submitted to the mentor through email, and in hardcopy at the closing meeting. - Map showing suitable locations for nest box locations – final product will be handed over on a jump drive provided by the mentor in .jpg format and ArcMap format, along with a hard copy. - A strategy for building, funding, placing, etc., the bird boxes – to be created in MsWord and handed over at the final meeting in hardcopy and on the jump drive. - A list of funding agencies that are willing to donate to the project – to be created in MsWord and handed over at the final meeting in hardcopy and on the jump drive. |
| Exclusions | <p>We are not responsible for:</p> <ul style="list-style-type: none"> - Purchasing bird box materials. - Creating and placing the bird boxes. - Determining suitable habitat in other conservation areas. |
| Stakeholders | <p>List the key players, internal and external to host organization, to be taken into consideration</p> <ul style="list-style-type: none"> ● Clients: park visitors, people who have donated to the project, birders. ● People to be consulted: Dave Pridham (Manager, environmental and technical services), Jessie James (Conservation Areas Coordinator) ● Co-operation: external companies will be asked if they are willing to donate materials for the bird boxes, and will be given tax receipts. |
| Scope | <p>List the limitations or boundaries for project</p> <ul style="list-style-type: none"> - Small budget - 55¢ per kilometre, at least 6 trips required. All other items must be approved before purchase. Printing will be paid for by the school, and the sponsor. - 12 Mondays, 8 hours a day - Success will be measured by all deliverables being completed on time, in a manner that the mentor of this project is pleased with. |
| Project Tasks and Timelines | <p>Refer to Gantt Chart attached in the appendix for deadlines as to when deliverables will be achieved.</p> |

| | |
|-------------------------------|---|
| | |
| Health and Safety Plan | Refer to Health and Safety Plan attached in the appendix |
| Background | Bird boxes have been placed in the park in the past, but are deteriorating and improperly located. The strategy template created by this team will be used in other conservation areas to implement bird boxes. |

9.6 Appendix F: Progress Report

Progress Report

Bird Nest Box Project – Kawartha Region Conservation Authority

Updated Gantt Chart

Green = Completed on time

Light Red = Due date extended

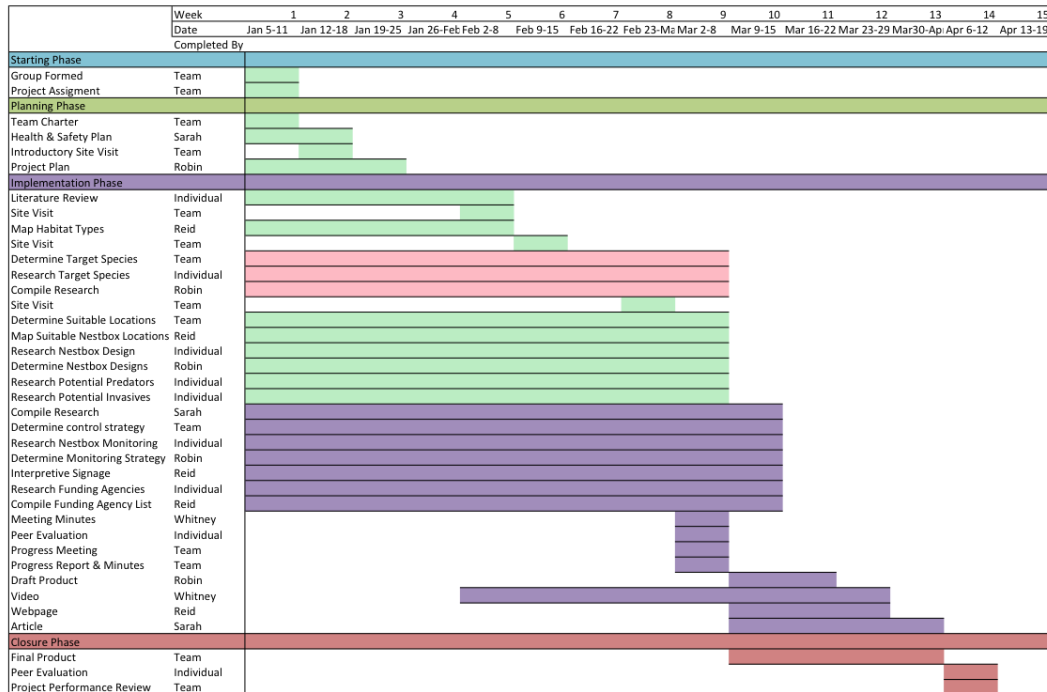

Meeting: January 20, 2014

In Attendance

Student Team: Reid Bentzen, Sarah Sinasac, Robin Brand, and Whitney Brennan

Kawartha Conservation Authority: Rob Stavinga

Minute taker: Whitney Brennan

Meeting Time: 3:00pm – 4:00pm

Agenda

- Update
 - Literature Reviews
 - Finalize Progress Meeting

- § Parking pass requirement
- § If in person or teleconference

- Discuss Final Product
- Flash Drive with Map

Meeting

- Update
 - Literature Reviews
 - § Economic topic – potential changing this topic due to minimal sources
 - Project Plan
 - § Rough completed and waiting to be finalized before signage
 - Finalize Progress Meeting
 - § Parking pass requirement –will get one in – can have it email it to Rob
 - Environmental Committee
 - § Currently planning on in person but may have to switch to teleconference
- Discuss Final Product
 - Implementation plan
 - Prioritized areas
 - Ways to go through implementation plans
 - § Steps of how to prioritize sites
 - § Threats to habitat to fix and get the maximum results for efforts for cheapest
 - § Scoring systems to determine where efforts should be placed
 - § Characterize conservation area of habitats and location as to where to start implementing
 - § Identify funding area (top 5) and top 5 best organizations to partner with (ie. monitoring, material)
 - § Characterization (1st part), plan is the second part (5 W's)
 - § Template for other conservations areas and process to make this work
 - § Can have next steps to complete the plan if we do not get to everything completed
 - Will provide a plan to provided a basis of implement plan (stewardship)
- Flash Drive with Map -Whitney
 - Received
 - Tatic – mapping software

Site Meeting: February 3, 2014

In Attendance

Student Team: Reid Bentzen, Sarah Sinasac, Robin Brand, and Whitney Brennan
 Kawartha Conservation Authority: Rob Stavinga

Minute taker: Whitney Brennan

Site Visit Time: 12:30pm – 3:00pm

Meeting Time: 3:00pm – 3:30pm

Agenda

- Site visit of Ken Reid Conservation Area
- Overview of progress on literature reviews and new topic
- Discuss up to date progress

Meeting

- Site Visit
 - Discussed discoveries and thoughts for bird box implementation along the Escarpment Trail
 - Discussed what to do as per old bird boxes that are located along the trail
 - § Record location, condition, and if decommission is necessary
- Literature Reviews
 - Discussed new topic: Appropriate materials to construct effective bird boxes
 - Progress of literature reviews and when they will be completed by
- Up to Date Progress
 - Ken Reid Conservation Map
 - § Showed summary map produced from ELC data provided by from Ken Reid Conservation Area
 - § To produce a summary map of overall conservation area with bird box installation regions identified
 - § To produce more focused maps on particular target areas to display where the bird boxes should be installed with GPS coordinates
 - Implementation Plan
 - § Simple, to the point, step-by-step
 - § Review the ones emailed by Rob to provide guidance to produce our own plan
 - § Other plans available online as well to provide more insight
 - Funding List
 - § To produce a list of potential funders who could contribute to this project
 - Local companies, home depot, rona, etc.
 - Minimum and maximum amounts that companies donate to projects
 - Progress Meeting
 - § Confirmed date and time with Rob
 - § Will need to obtain a parking pass – wants it digitally sent to him

· **TO BE COMPLETED BY NEXT MEETING**

- Parking pass and car information - Robin
- Have a table of contents for implantation plan - Sarah
- Compile a list of potential funders - Sarah
- Provide examples for bird box designs - Robin
- Produce map of Escarpment Trail - Reid
- Progress meeting agenda to be emailed in advance - Whitney
- Location and time to be emailed in advance -Whitney

Meeting: February 7, 2014

In Attendance

Student Team: Reid Bentzen, Sarah Sinasac, Robin Brand, and Whitney Brennan

Minute taker: Whitney Brennan

Meeting Time: 11:30am – 12:30pm

Agenda

- Progress Meeting Agenda
- Implementation Plan Table of Contents
- Bird Box Design
- Parking Pass Information

Meeting

- Progress Meeting Agenda
 - Completed agenda for progress meeting
 - Emailed to group members, Rob, and Sara
- Implementation Plan Table of Contents
 - Reviewed other implantation plans to compile table of contents
 - Completed a rough template of table of contents
- Bird Box Design
 - Compiled potential bird box design for chickadee
 - Will continue to find bird box designs for other species
- Parking Pass Information
 - Emailed Rob for car information so parking pass could be emailed to him before meeting

TO BE COMPLETED BEFORE NEXT MEETING

- Map of Escarpment Trail – Reid and Whitney
- Powerpoint Presentation of current draft products - Sarah
- Printed agendas for progress meeting - Robin

Progress Meeting: February 10, 2014

In Attendance

Student Team: Reid Bentzen, Sarah Sinasac, Robin Brand, and Whitney Brennan

Sir Sandford Fleming College: Sara Kelly

Kawartha Conservation Authority: Rob Stavinga

Minute taker: Whitney Brennan

Meeting Time: 2:00pm – 3:00pm

Agenda

- Update of Progress
- Table of Contents for Implementation Plan
- Maps of Ken Reid Conservation Area
- Bird Box Design
- Potential Funder List
- Further Progress

Meeting

1. Update of Project's Progress
 - a. Literature Reviews
 - i. Disturbances to Cavity Nesters
 - Snag, recreation uses
 - ii. Nest Box Materials and Construction
 - Chickadee and bluebirds, predation protection
 - iii. Habitat Requirements
 - Owls, wood ducks, bluebirds, woodpeckers as keystone species
 - iv. Monitoring Bird Boxes
 - Monitoring number of eggs, presence of pests, new growth forest
 - b. Site Visits
 - i. Site Visit on January 18th and February 3rd, 2014
2. Table of Contents for Implementation Plan
 - a. Review rough table of contents for implantation plan
 - Section for managing predators and pests
 - Trail section: chart to display timeline for completion of nest boxes, materials needed, monitoring practices, areas prioritized
 - Potential flow chart
 - Next step section: interpretation network (signage), grant writing, volunteer monitoring, phases (Windy Ridge second phase), etc.
 - b. Any other suggested areas to add to plan
3. Maps for Ken Reid Conservation Area

- a. ELC map of Ken Reid with overview of habitats
- b. Escarpment trail map
 - GPS points on as to where potential habitat could exist and where there are current nest boxes that are present
 - Recommended for chickadees
 - Hill above trail by road is also Ken Reid property
- c. Shapefile for trails would be helpful to orientate location within conservation area

4. Bird Box Design

- a. Chickadee bird box design
 - PVC tubes – cheap method, volunteer/community members to paint tubes with non-toxic paint to blend in with landscape
 - Can be obtained from construction excess and be reusable material
- b. Future species bird box designs
 - Provide different types of designs and prioritize each with what would be the most beneficial and cost effective
 - Refer back to literature review when writing this section
 - Appendix with templates for bird boxes and the components for each to make it user friendly

5. Potential Funders List

- a. Community members
- b. Non-profit organizations
 - i. Volunteer sources
- c. Community grant from Ontario Trillium
- d. Rona Sponsorship
- e. TD Funds of the Environment – Maintenance Plan
- f. Youth organizations for construction
 - i. High school wood workshop class
 - ii. Scouts / Girl Guides

Notes:

- Fleming College – technical school in Peterborough
- Local Fund – Chest Fund- contributed \$5000 to community garden at Fleming
 - Sara Kelly mentioned
- View what companies/organizations have funded in the past and what projects they would target
 - With related projects these become organizations of higher priority and targets
- Trillium contains database of past applications
- Rank funders: most likely to least likely

6. Further Progress

- a. Future Site Visits
 - i. Trails that will be evaluating next for potential habitats

- ii. Determine Habitats Present on Site
 1. Record areas of high priority
 2. How to determine the priority – values/requirements
 - Risk vs. sustainability – scoring system
 - How good the area is and the existing issues
 - Determine top species for habitat locations
 - Ways to improve that habitat by nest boxes
 - Consider future growth of vegetation
 - a. Future Maps
 - iii. Develop maps for bird habitats in various regions in Ken Reid
 - b. Video Ideas
 - iv. Existing bird boxes where there and how not in use and why we are implementing more efficient bird boxes
 - v. Target species that are present and bird box design requirements
 - vi. Step – by – step process of implantation plan
 - How to make a particular nest box – step by step for community members to follow – ie. PCV pipes for chickadees
 - Monitoring – what is involved, maintenance, cleaning, why to maintain bird boxes, assessing for damages
 - Will provide public service

Additional Meeting Notes:

- Bird Atlas contains bird species that are present within the Ken Reid Conservation Area
- Dave Wood – talk to in regards to cleaning nest boxes on campus
- If needed, PCV could be obtained from hatchery or Sara Kelly for potential sample
- Media consent forms from Ken Reid will be emailed via Rob
- Rob away from Feb. 21st to March 2nd

9.7 Appendix G: Literature Reviews

Literature Review 1: Potential Disturbances Affecting Cavity Nesting Birds

Reid Bentzen

Introduction

Disturbance plays an important role in the environment by affecting the structure and function of an ecosystem. This paper identifies the potential disturbances affecting cavity-nesting birds at Ken Reid Conservation Park. One of the main disturbances that could affect these types of birds is the availability of cavities. One of the solutions is creating nest boxes, but artificial cavities pose other potential risks. **This report investigates potential disturbances for cavity nesters in both artificial and natural habitats.**

Ardia, D. R., Pérez, J. H., & Clotfelter, E. D. (2006). Nest box orientation affects internal temperature and nest site selection by Tree Swallows. *Journal of Field Ornithology*, 77(3), 339-344.

This report investigates the affects of nest microclimates. This is because they can affect the overall potential for offspring survival this is because of egg viability and impacts the energy balance of incubating adults. A solution for this issue is the orientation of the nest boxes. The reasoning behind this is to optimize sun exposure and to minimize sun exposure on ambient conditions. The report investigates nest orientation preferences in a population of Tree Swallows and compares temperatures inside boxes as a function of entrance orientation. This report suggests that Tree Swallows have a preference on the orientation of the nest box and that is reliant of the temperature inside the nest box. The results of this article conclude that Tree Swallows prefer south and east facing boxes during the first half of the breeding season when it was warmer than other boxes. There is no preference in nest box orientation during the second half of the breeding season, and there is no correlation between nest box orientation and box temperature.

Blewett, C. M., & Marzluff, J. M. (2005). Effects of urban sprawl on snags and the abundance and productivity of cavity-nesting birds. *The Condor*, 107(3), 678-693.

This journal article is about how the effects of how urban sprawl can negatively affect cavity-nesting birds. The article states that cavity-nesting birds may be especially sensitive to urbanization because they depend on snags for nesting, roosting, and foraging. Some of the reasons why snags are removed from habitats include: initial construction for safety reasons, and over time by homeowners and increased exposure to wind along newly created edges. There is strong evidence of cavity-nesting bird densities and nesting success decline if snag densities are low or snags with appropriate characteristics are not available. This study used 49 1-km² suburban landscapes within a 3200 km² of temperate, moist forest around Seattle, Washington. Each study site included built portions (single family residents) and 37 sites also had forested portions. Forests were predominately coniferous. This article concludes that retaining portions of second growth forest in a rapidly urbanizing region appears

to be an effective way to providing breeding sites for a diversity of cavity-nesting birds. Another one of the findings is there are few occurrences of cavity nesting birds in suburban areas. This is because of fewer trees and less snags.

Czeszczewik, D., Walankiewicz, W., & Stanska, M. (2008). Small mammals in nests of cavity-nesting birds: Why should ornithologists study rodents?. *Canadian Journal of Zoology*, 86(4), 286-293.

This article is about the potential risks that affect cavity-nesting birds in the form of mammalian predation. The article states, "In temperate forests, both natural cavities and nest boxes are breeding sites and shelters for numerous animals... the availability and quality of these sites influence the breeding success of birds and mammals". The article explains that mammals could affect birds' breeding performance by destroying eggs and nestlings, which forces birds to use different strategies to avoid mammalian predators. This article explains that mammalian predation is an essential factor in lowering breeding success or limiting bird numbers. The focus of this paper was to analyze the frequency of small-mammal encounters in natural cavities and nest boxes containing nests of flycatchers and titmice in managed and old growth forest stands. Cavities and nest boxes without birds nesting inside them were monitored. After the sixteen years of study the results showed that of the 748 natural cavities and the 250 nest boxes mammals were observed in tree cavities fifteen times. In those fifteen occurrences twelve of them destroyed the birds broods. This study suggests that snakes and rodents could also be highly important nest predators.

Dawson, R. D., Lawrie, C. C., & O'Brien, E. L. (2005). The importance of microclimate variation in determining size, growth and survival of avian offspring: experimental evidence from a cavity nesting passerine. *Oecologia*, 144(3), 499-507.

This report highlights that organisms maximize fitness by solving numerous tradeoffs. The tradeoffs occur because there are limited amounts of resources such as time and energy. An organism cannot have both of these life history traits equal as one is going to be lower than another. This study focuses on the thermal environment of the nest because it is crucial in determining the allocation strategy of offspring. For example a cooler nest may influence offspring to allocate more energy to keeping themselves warm, instead of investing in growth and or immune response. Alternatively a warmer nest may increase offspring growth and other traits. This report investigates how variation in microclimates affects the survival, growth, and cell mediated immune response in nestling tree swallows. This was completed by artificially heating nest boxes throughout the brooding and rearing period. This article suggests from their own and previous research that (I think this is meant to be parents???)chicks that are in colder climates spend less time foraging and more time brooding. There is evidence that broods with heated nests were less likely to suffer brood reduction, and as consequence heated nests fledged significantly more offspring than did control nests.

Froke, J. B. (1983, June). The role of nest boxes in bird research and management. In JS Davis, GW Goodwin, and RA Ockenfels, tech. coords. Snag habitat management: proceedings of the symposium. US For. Serv. Gen. Tech. Rep. RM-99 (pp. 10-13).

This paper presents historical background information, and discusses implications of nest box studies for wildlife management in natural and artificial cavity habitats. This report highlights that insectivorous cavity-nesting species have continued to justify their management using nest-boxes to the present day. Examples of the importance in managing cavity nesters are: “The Bureau of Biological Survey, performed extensive experiments using nest boxes to increase numbers of birds for control of nut weevils and other injurious insects in orchards”. There have been numerous major research programs dedicated to increasing insectivorous bird populations in timber and food crop environments. Lastly, this paper states, “Flexibility of the design and placement of nest sites provides for limitless experimentation, and hence a greater insight to the relationships of the nesting bird and its physical and biological environment”.

Mänd, R., Tilgar, V., & Lõhmus, A. (2005). Providing nest boxes for hole-nesting birds—Does habitat matter?. *Biodiversity & Conservation*, 14(8), 1823-1840.

This report investigates the concept of ecological trap and how it affects cavity-nesting birds, as well as how nest boxes may be an ecological trap. An ecological trap is described as areas with high quality cavities or patches that may be under used if individuals cannot distinguish or reach them and that low quality patches may be over used because they are attractive and easy to reach. Therefore an ecological trap is a preferred but worse habitat. An ecological trap may become an “attractive sink” if mortality rates are higher than birth rates. There are three main ways that ecological traps are created. The environment of the organism altered, causing natural behavior, but there is no longer a match between behavior and environment. An example of this would be introducing new predators in an already food rich environment. The second reason being creating features that mimic natural features, which can mislead organisms. Interestingly the creation of nest boxes is one of the causes of this type of ecological trap. An example of this was placing Wood Duck nest boxes in clusters instead of placing them further apart. The results showed that there was higher brood parasitism, which was detrimental to reproduction rates. This report focused on looking at a population of Great Tit breeding in nest boxes in patchy deciduous woodlands and large pine forests. They measured nest box occupancy, food conditions during nestling conditions, and fitness approximations. This report wanted to understand whether deciduous woods are still a better habitat even after cavity shortage has been eliminated in coniferous forests. The results of the study showed that even though nest boxes were at the same density in both types of forest, yet nest boxes in deciduous forests were almost twice as frequent compared to coniferous forest. The report concludes that, “The higher occupancy of nest boxes in deciduous stands is likely to be related to a preference of great tits for deciduous woods rather than to shortage of natural cavities”.

Remacha, C., & Delgado, J. A. (2009). Spatial nest-box selection of cavity-nesting bird species in response to proximity to recreational infrastructures. *Landscape and Urban Planning*, 93(1), 46-53.

This paper looks at how the recreational land is expanding and how it is affecting cavity-nesting birds. Some of the issues created from the creation of recreational areas are more edge, higher amounts

of human presence, which could interfere with foraging behaviour, selection of habitat patches, and reproduction. Human disturbance on birds may be dependent on species-specific tolerances. This could mean that some species prefer human activities around their habitat, causing higher densities, and higher survival rates. On the other hand species that are more sensitive could have declines in populations, and lower survival rates. There have been recent studies that prove that human activities influence decisions by birds with nest selection. Nest selection is known to have serious consequences regarding fitness and survival rates. This article studied, "The potential influence of the location of recreational infrastructures on nest-box use by small cavity nesting passerine species in an afforested area recently opened to restricted recreational use". They expected to find a negative influence of human disturbance on whole bird communities, with higher frequencies of unused nest boxes in locations close to human disturbance sources. The results showed that, "Buildings and trails have been found to influence the distribution of sensitive bird species in greenways, but in our study area, the influence on nest-box selection patterns appears to be mediated by proximity to buildings rather than location of trails".

Schlaepfer, M. A., Runge, M. C., & Sherman, P. W. (2002). Ecological and evolutionary traps. *Trends in Ecology & Evolution*, 17(10), 474-480.

This report goes into detail about what ecological traps are and how they affect cavity-nesting birds. Organisms often use indirect cues in their physical environment to guide their choice of habitat. These cues can reflect current habitat quality, but more often they enable individuals to anticipate the future state of habitat. The term is defined as "The situation in which a bird's choice of nesting habitat led to nest failure because of a recent anthropogenic change in the environment that broke the normal cue-habitat quality correlation". The ecological trap is important to understand because it reveals how rapidly anthropogenic environmental changes can cause organisms to evaluate incorrectly the quality of their altered habitat.

University of Washington. (2014). Conservation: Do dogs keep birds away from urban parks? Retrieved on February 8th, 2014, from: <http://conservationmagazine.org/2013/11/dogs-keep-birds-away-urban-parks/>

This news article describes a study done in Israel. The study investigated 25 public parks and counted from one to two spots in each park. They counted about 21-25 for each park. They ended up recording 14,000 birds from 65 species. Near by, trees, shrubs, people, cats, and dogs were recorded. They discovered that birds prefer areas that are larger, and have trees and shrubs rather than gardens and lawns. Parks with higher human and canine activity also had lower species of birds. They suggested having larger parks with areas with trees and shrubs, and keeping dogs on leashes.

Conclusion

There are many potential risks that could affect cavity-nesting birds. It is important to understand these risks, which affect these species, and solutions to help mitigate these potential

disturbances. This is especially true when creating nest boxes because this is the main strategy for protecting and mitigating these types of birds. Nest boxes pose different risks such as, microclimates, predation, and ecological traps. These risks could affect the success of the nest boxes, and survival rates of the birds. Therefore it's important when creating nest boxes that these risks are managed.

Literature Review 2: Artificial Nesting Structure Construction and Placement

Robin Brand

Introduction

Cavity nesting birds are among the most threatened birds in North America due to habitat loss. Woodpeckers are primary excavators, which excavate a new cavity for nesting each year; their old unused cavities are used by cavity nesting species such as ducks, owls and other birds. **Artificial nesting structures can be used to mitigate the effects of habitat loss and increase reproductive success for cavity nesting birds by increasing the number of suitable nesting sites.** Many factors affect the success of nesting structures including nest box directional orientation, temperature, placement, and predator guards. This document will review the literature to obtain information on how to construct and place successful artificial nesting structures for cavity nesting species.

Butler, M., Whitman, B., Dufty, A. (2009). Nest box temperature and hatching success of American Kestrels varies with nest box orientation. *The Wilson Journal of Ornithology*. 121 (4): 778 – 782.

This study looked at the orientation dependent differences in nest box microclimate related to the American kestrel reproductive success. They constructed wooden nest boxes (21 x 21 x 48cm), which were placed in different locations facing different directions, and conducted two separate experiments. The first experiment did not allow kestrel access and measured daily temperature, humidity and light using data loggers. They found that empty boxes facing west were 0.6 ° C cooler than boxes which faced south or east and had 20% lower relative humidity levels. The second experiment allowed kestrel access and documented nest choice based on entrance orientation as well as nest success. It was found that clutches in boxes, which faced southwest had a lower hatching success than clutches facing other directions. This article directly related to our bird box implementation project as nest box orientation can affect nest choice as well as nest success.

Cooper, C., Bonter, D. Erickson, L. (2008). Looking for the perfect fixer upper. *Birdscope*. Available at: http://www.birds.cornell.edu/Publications/Birdscope/Summer2008/fixer_upper.html. [Accessed February 9, 2014].

Black-capped Chickadees accept a wide variety of habitats, however they are fussy about nest design as they prefer to excavate their own cavities. It was found that standard nest structures were rarely used by chickadees even when filled with wood shavings. They found that artificial tree snags made of PVC

pipe however was readily accepted by chickadees. In 2005 a study was conducted near the Lab of Ornithology Sapsucker Woods where PVC artificial snags and standard nest boxes were placed and oriented in the same direction. It was found that chickadees excavated 60 – 70 percent of the artificial snags and only 40 – 50 percent of the nest boxes. This report is directly related to our nest box implementation project as Black-capped Chickadees are a target species. By implementing PVC artificial snags instead of standard nest boxes we can increase the success of artificial nesting structures for chickadees.

Cornell Lab of Ornithology. Nest Watch: Managing House Sparrows and European Starlings. Available at: <http://nestwatch.org/learn/nest-boxresourcecenter/managing-house-sparrows-and-european-starlings>. [Accessed February 10, 2014].

Invasive species are currently recognized as one of the main threats to global biodiversity. House Sparrows and European Starlings were both introduced to North America in the 19th century. Both species outcompete native cavity nesting birds and are known to destroy nests and eggs, and often kill nestlings and adults while taking over an occupied nest site. House sparrows and starlings prefer to nest near human habitations therefore by placing boxes in natural areas nest box takeover can be avoided. Starlings can be excluded by making the nest hole smaller than 1 ½", however house sparrows can fit in holes as small as 1 1/8". Once house sparrows have started nesting, removing nest materials every few days can discourage them from taking over the nesting structure. This document provides information on avoiding nest takeover, which is relevant to our nest box project as Ken Reid conservation area is near human habitations. With the correct placement and ensuring entrance hole size is small enough it can be ensured that target species inhabit the nesting structures instead of invasive species such as the House Sparrow and European Starling.

Dhondt, A., Phillips, T. (2001). A Question of Preference: Does the orientation of a nest box affect the breeding success of cavity nesting birds. *Cornell Lab of Ornithology*. 15(2).

Cavity nesting birds choose some nest boxes over others. Previous research has found that the size and shape of entrance holes as well as flat or slanted roofs and nest box orientation has an effect on nest box choice. It has been found that bluebirds prefer east and north facing boxes. It was found that nest boxes facing in eastern directions fledged on average more young than boxes facing in other directions. It is suggested that this is due to the microclimate within the box. Boxes facing east warm up earlier in the morning giving a small temperature advantage to birds nesting in boxes facing that direction, this also allows them to avoid the hot afternoon sun. They found that the mean number of nestlings increased with latitude therefore there is a benefit to breeding in east facing nest boxes in northern latitudes. This article is directly related to our project for implementing artificial nesting structures for cavity nesting birds. This article once again supports orienting nesting structures towards

the east.

Ducks Unlimited. (2008). Build a Duck Nest Box. Available at: www.ducks.ca [Accessed February 9, 2014].

Wood ducks, Goldeneyes, Mergansers and Buffleheads are all cavity nesting ducks, which utilize abandoned woodpecker holes or natural tree cavities, as well as constructed nest boxes. Cedar is an ideal material because it is naturally resistant to weather and insects. Cavity nesting ducks do not carry nesting materials therefore it is important to place four to six inches of wood shavings in the bottom of the nest box, it is important to not use sawdust as it can suffocate ducklings. Nest boxes should be placed near wooded wetlands and mounted on tree trunks or steel poles beside or above the water. Boxes should be placed four to six feet above the land or water. The entrance hole should face the water. This document is relevant as it provides information on how to build a successful nest box for waterfowl and also includes specific measurements of boxes to target species. Waterfowl are target species for this project and therefore this information will aid in the implementation of successful cavity nesting duck structures.

Lowther, P. (2012). Does nest box size impact clutch size of House Sparrows. *The Wilson Journal of Ornithology*. 124 (2): 384 – 389.

This study looked at the effects of nest box size on clutch size of House Sparrows in Cook County Illinois. Internal nest box dimensions ranged from 112 cm² to 221 cm². There was a significant correlation between clutch size and the area of the nest box with mean clutch size varying from 4.49 eggs in a small nest box to 4.77 eggs in the large nest box. Other measures of breeding success such as hatching and fledging success had no significant relationship with nest box size. This article is relevant to our project as many nest boxes will likely be constructed by volunteers, decreasing the consistency of nest box size. It is important to know that nest box size does not influence the clutch size or success of the cavity nesting birds.

Natural Resources Conservation Service. (2001). Artificial Nesting Structures. *Fish and Wildlife Habitat Management*. Available at: <http://www.wildlifehc.org> [Accessed February 6, 2014].

The most effective artificial nesting structures are installed in close proximity to brood rearing habitat with adequate escape, a reliable source of food and water as well as other elements of the habitat of the target species. This document was used as an introduction to the use of artificial nesting structures to enhance wildlife habitats. The success of artificial nesting structure is dependent on materials used, structure, design and placement as well as the use of predator guards. Materials should be wood cedar is best but also cypress, redwood or pine. ¾ inch boards are best and 3-4 inches of wood

shavings should be used. Boxes for waterfowl should be placed in wooded areas close to or directly over water. They prefer entrances that face away from prevailing winds. Three main types of predator guards include conical, pipe, and sheet metal tree guard. Four ¼ inch holes should be drilled in the bottom of the nest box for drainage and ventilation slits should be provided on both sides under the roof overhang. This document provides guidelines for constructing and placing artificial nesting structures with a guide for species-specific nest box requirements.

Sacilotto, K., Anderson, J. (2005). Avian nest box use on islands in the Ohio River. *Northeastern Naturalist*. 12 (4): 403 – 410

This study looked at the effects of nest box placement and surrounding habitat characteristics on nest box use for passerines. The study was conducted on the Ohio River Islands National Wildlife Refuge. Sixteen wooden nest boxes were placed on three separate islands, eight on the back channel side and eight on the navigational side. Boxes were oriented facing upstream, downstream, away from the island and toward the island. Birds used 74% of the nest boxes; Wren species utilized the boxes most at 47%. Nests located in the least visible nest boxes were filled with moss nests mainly Carolina Chickadee, whereas visible nest boxes were used by House Wrens. Nest boxes with southeast orientation were occupied the most. This article is relevant for as this project expands nest box plans will be extended to different conservation areas and will target several different species. On island habitats orientation with regards to upstream, downstream, towards, and away from the island there was little correlation however most occupied nest boxes were oriented to the east.

Svatora, S., Shamir, L. (2012). Improving Eastern Bluebird nest box performance using computer analysis of satellite images. *Computational Ecology and Software*. 2 (2): 96 – 102.

Nest box programs have been used to facilitate population growth of Eastern Bluebirds. This study looked at the preferences and performance of nest boxes using satellite images of nest locations combined with the nesting statistics. The method was based on computer analysis of the edge directionality in a satellite image of the area around the box. This was used to assess the future performance of boxes before they were placed in the field. The experiment was based on the nest boxes placed for the Cornell Lab of Ornithology NestWatch project. Satellite images for each pair of boxes was gathered from Google Earth. By using computer analysis they found that there was a correlation between bluebird nesting attempts and the visual content of the 20m satellite images, which showed that Eastern Bluebirds are sensitive to the landscape around the box when making their site selection. The numerical image content descriptors that had the strongest correlation with the nesting attempts were the edge directionality features. They concluded that edge directionality could be used to predict the efficacy of bluebird nest box placement. The results suggested that bluebirds use visual patterns found in the landscape around the boxes to determine whether to use the site to nest or not. Selecting proper habitat, placing boxes in appropriate distances apart, grouping boxes in pairs, as well as

analyzing the directional representation of the surrounding landscape could lead to increased occupancy. This is directly related to our project as the Eastern Bluebird is one of our target species. We now know that placement is key for the success of artificial nesting structures for this species.

Conclusion:

From a review of the literature it has been determined that when possible artificial nesting structures should be oriented in an easterly direction to increase likelihood of nest box choice while increasing nest box success. Predator guards should be used to deter raccoons, and snakes as well as squirrels. Predator guard types such as conical, pipe, and sheet metal tree guard should be utilized, each of the styles are equally effective and can therefore be chosen based on price. Nest box size does not affect clutch size or success and therefore nesting structures can be constructed by the public as variation in sizing will not affect the success of the nest box. Cedar and pine should be used for nest box construction when available, and PVC piping can be used for the construction of Black-capped Chickadee nesting structures. With the successful implementation of the artificial nesting structure project we will be able to increase the reproductive success for cavity nesting birds within the Kawartha Conservation Areas by increasing the number of suitable nesting sites available.

Literature Review 3: Habitat Requirements of Cavity Nesters

Whitney Brennan

Introduction

Cavity nesting bird species utilize enclosed areas in trees for breeding and nesting habitats. Two types of cavity nesters are primary and secondary cavity nesters. Primary cavity nesters excavate cavities in wooded structures for their own use, where secondary cavity nesters are bird species that utilize cavities created by primary cavity nesters or from decaying trees. Primary cavity nesters provide suitable cavities and are important keystone species for secondary cavity nesters' reproductive success. **Nesting habitat selection by secondary cavity nesting species provides optimal macro- and microhabitats to increase reproductive success.** Through evaluating habitat requirements of secondary cavity species, optimal habitat selection can be established to optimize success of nest box programs.

Hartke, K. M., & Hepp, G. R. (2004). Habitat use and preferences of breeding female wood ducks. *Journal of Wildlife Management*, 68(1), 84-93.

Female wood ducks (*Aix sponsa*) nutritional acquisition varies depending on the reproductive state. Plants are consumed prior to prelaying and invertebrates are consumed during egg production. The objective of this study was to determine habitat use variation during prelaying and egg-laying stages due to the nutrient requirements and to examine the sources of variation in habitat use, such as: year, age, and nesting date. The study also examined the habitat preferences of females by comparing the use and availability of habitats. The study was conducted at Eufaula National Wildlife Refuge that consists of

various water and forested habitats for wood ducks. Movements and habitat uses of adult and yearling females were monitored during January to May in 1999 and 2000 through radio transmitters. In 1999, twenty-nine females were radio-marked and thirty-three females in 2000. Throughout the study, forty-seven nesting females were analyzed. The home range size of the breeding females averaged at 367ha and was determined to not vary during the reproductive period of wood ducks. It was determined that habitat use varied between years, female age, and nest initiation periods. Managed impoundments and lake-influenced wetland habitats were most preferred by wood ducks since wetlands contribute to the nutritional demands of breeding female wood duck and nesting habitats have been viewed to be less than 0.5km from wetland or shoreline. Providing habitat diversity will contribute to the increase in the probability the needs of a breeding female wood duck would be met. The methods of this study demonstrate the measures taken throughout the study so this study can be replicated for future studies to be conducted. The authors defined the reproduction periods, mapping techniques, and calculation measures. This study provides insight and a better understanding of methods that will contribute to future habitat conservation and management measures. This study contributes to this project since it demonstrate the requirements wood ducks have in their nesting habitat selection to the vicinity of wetlands.

James, R. D. (1984). Habitat management guidelines for cavity-nesting birds in Ontario. *Ontario Ministry of Natural Resources*.

The scope of this document is to provide habitat requirements of cavity nesting species and management considerations for all species against various factors affecting nesting sites. This Ministry of Natural Resource document evaluates cavity nester requirements by display specie distribution in Ontario, habitat characteristics, and nesting requirements for each cavity nesting species. There are twenty-seven species described throughout the document to provide insight on the requirements for each, along with additional resources for further knowledge. The authors also provide management guidelines and nest box designs that will contribute to the promotion of cavity nesting habitats. This document contributes to further management plans and nest box programs to optimize the reproductive success of cavity nesting birds during the breeding season. The document is user-friendly that all audience can utilize to obtain greater knowledge on cavity nesting species in Ontario.

Pinkowski, B. C. (1976). Use of tree cavities by nesting Eastern Bluebirds. *The Journal of Wildlife Management*, 556-563.

The purpose of this study was to determine and describe natural tree cavities utilized by eastern bluebirds (*Sialia sialis*) throughout two study areas. This study was also conducted to determine the effects of various land use practices and competition for nesting sites. The two study areas were: Huron National Forest and Stony Creek in Michigan. Parameters that were measured throughout the study were: cavity height, distance from base of tree to bottom of entrance, vertical and horizontal averages for cavity dimensions (entrance, depth, bottom of entrance to deepest point in cavity), cavities interior and exterior diameter, and diameter of tree at nest level. There were three classes of cavities determined throughout the study: woodpecker abandoned cavities, fire-related cavities, and cavities

from natural decay. It was determined that 88.8 percent of the cavities evaluated were in dead trees. The authors found that greatest amount of nest cavities were located in pine or oak trees and woodpeckers created 77.6 percent of the cavities. Woodpecker constructed cavities were more evident at Stony Creek which were dominantly utilized by blue birds due to the southeastern entrance and size. The southeast exposure provides protection from prevailing winds and insulation from the heat generated by the morning sun to control the microclimate in the cavity. The study determined that bluebirds selected cavities with smaller entrances and preferred woodpecker nests to other cavity types. The selected cavity could have been chosen due to size or starling competition since the entrance sizes were less than 4.1cm, which starlings cannot enter. The authors concluded that nest boxes were preferred over natural cavities at Stony Creek due to the variables of nest location and dimensions. The authors provided more information on the habitat requirements of nesting eastern bluebirds and their dependence on woodpeckers to create cavities and demonstrate that eastern bluebirds are attracted to cleared areas. The authors provide knowledge on the deterrents to eastern bluebirds by even-aged timber management and dead tree removal can impact cavity availability for nesting bluebirds. This study is well written for all audiences and provides insight on management practices to promote nesting habitats for eastern bluebirds and the importance of specie relationships.

Remm, J., Lõhmus, A., & Remm, K. (2006). Tree cavities in riverine forests: What determines their occurrence and use by hole-nesting passerines?. *Forest Ecology and Management*, 221(1), 267-277.

Woodpecker species are keystone species since they are major contributors to providing nesting cavities for secondary cavity nesters. This study was conducted to determine the natural variation of cavity features and qualities in mature floodplain forests, instead of evaluating nest boxes, which most studies have done. The purpose of this study was to assess the relative importance of various macro- and microhabitat characteristics that are utilized by cavity nesters and to evaluate woodpecker's roles as a keystone species. The study was performed in Alam-Pedja Nature Reserve in Estonia where the terrain consisted of: 55% forest, 30% mires, and 10% meadows. From 1999-2003 sixteen stands were evaluated through multiple surveys conducted over the years. It was determined that 68% of discovered tree-holes were suitable for secondary cavity nesters and woodpeckers excavated 88% of the suitable cavities. Large broadleaved trees, where the diameter at breast height is greater than 30 cm, are important to retain in forested areas since these species were determined to be important to cavity nesters. Natural and woodpecker excavated cavities occurred in similar habitats that was primarily determined by tree species and condition, stand type, and proximity of other cavities. Overall it was determined that the value of woodpeckers a keystone species largely depends on the occurrence of natural cavities. Due to multiple studies evaluating nest boxes, this article allows for further knowledge on the natural nest habitat characteristics. Researchers are able to compile the data and further explore habitat requirements of secondary cavity nesters that can be provided from keystone species.

Rendell, W. B., & Robertson, R. J. (1989). Nest-site characteristics, reproductive success and cavity availability for Tree Swallows breeding in natural cavities. *Condor*, 875-885.

The purpose of this study is to examine nest-site characteristics of cavities occupied by tree swallows

(*Tachycineta bicolor*) and to evaluate the influences on reproductive success. The study also examines the factors influencing cavity availability. The study was conducted from 1986 to 1987 in Kingston, Ontario at Allan's Pond and Osprey Marsh. Surveys by canoe were conducted to determine the location of cavities occupied by tree swallows throughout the breeding season and each site was mapped to scale. Measurements of forty-eight tree swallow nest sites were taken, along with twenty interspecific competitor nest sites and nineteen of unoccupied nesting cavities. Measurements included snag dimensions, cavity height above water, cavity dimensions, entrance dimensions, and distance to nearest nesting site. Large variances in tree swallow nesting site characteristics were evident from the study. Tree swallows were determined to utilize low cavities with small cavity entrances and volumes, along with utilizing high cavities with large cavity entrances and volumes. Nesting site cavities could be preferred due to predation and competition variables that will allow tree sparrows to enhance their reproductive success. Tree swallows were also uniformly spaced to conspecific species in the surrounding area. It was determined that cavity height and floor area influence the reproductive success of tree swallows. It was viewed that cavities at greater height were less preyed on and females laid larger clutch sizes when larger floor areas were present. Influences that impact nest-site availability was through destruction of predators, snag fall, territorial defense from conspecifics species, and aggressive interactions between larger species. The authors concluded that tree swallows avoid intraspecific competition and occupy another optimal nesting site farther from intraspecific territories and cavity height and floor area contribute to the reproductive success of tree swallows. This study provides the first detailed description of tree swallow nesting sites and the factors that influence cavity selection. This study provides knowledge for further research to be undertaken to further expand knowledge on tree swallow nest selection behaviour.

Robertson, R. J., & Rendell, W. B. (1990). A comparison of the breeding ecology of a secondary cavity nesting bird, the Tree Swallow (*Tachycineta bicolor*), in nest boxes and natural cavities. *Canadian Journal of Zoology*, 68(5), 1046-1052.

This study compared the ecology of tree swallows that were breeding in natural cavities compared to nest boxes to determine if nest box populations accurately model natural populations. Two sites, Allan's Pond and Osprey Marsh, located 8km apart were evaluated for tree swallows utilizing natural cavities. The study examined the natural cavity nesters populations, grids of nest boxes, reproduction, and tree swallow survivorship. Throughout the study, nest site dispersion and cavity height were two of the characteristics that were similarly found between both nesting habitats. Tree swallow nesting cavities are dispersed amongst the habitat, orientating them to be 27m from nearest neighbor for natural cavities and 28m in the nest boxes. It was viewed that cavity entrances were larger for natural cavities than nest boxes, which led to a higher interspecific competition and clutch sizes were smaller since the floor space available in natural cavities are smaller than nest boxes. Clutch size ranged from four to seven eggs in nest boxes, while natural cavity clutch size ranged from three to six eggs. Five interspecific competitors, European starling, common grackles, northern flickers, great crest flycatchers, and eastern blue bird, were present for natural nest sites but only one interspecific competitor, the eastern bluebird, was present for nest box sites. The cavity height contributed to the reproductive success of tree swallows since nests higher in the tree are less likely to be preyed on. The authors concluded that the

breeding ecology of nesting tree swallows differs considerably for the clutch size and conditions present with nesting cavity selection. Tree swallows settled at suitable nest box habitats over natural cavities since a greater yield for reproductive success and reduced competition present with this nesting habitat selection. This article provides further knowledge on the variance in breeding ecology of tree swallows and their habitat requirements to yield the highest reproductive success. For future studies the authors suggest that nest box studies should be compared to natural habitats for birds to determine the variance in breeding ecology between species in natural nesting cavities and nest boxes.

Stanback, M. T., Mercadante, A. N., Cline, E. L., Burke, T. H., & Roth, J. E. (2013). Cavity Depth, Not Experience, Determines Nest Height In Eastern Bluebirds. *The Wilson Journal of Ornithology*, 125(2), 301-306.

Eastern Bluebirds (*Sialia sialis*) are multi-brooded secondary cavity nesters that often reuse nest cavities throughout the spring and summer seasons. Due to being secondary nesters, various nest sizes exist due to the adjustment to cover the overall floor area. Female eastern bluebirds construct the majority of the nest from grass or pine needles while lining the inner layer of the nest with finer materials. This study examines the influence cavity depth has on nest height and the influence of initial shallow cavity nest sites have on height of the subsequent nest height. Subsequent nest heights were examined in the same breeding season to determine if the selected height corresponded to the initial nest height. Initial nests occur during the spring and subsequent nests occur during the summer. Cylindrical wood-concrete nest boxes were installed at 1.75m in height and equipped with a protector guard from predation. It was discovered that subsequent nests built in deep boxes were significantly taller than the initial shallow nest. This could have occurred due to multiple variances such as: temperature, season, or box depth. The authors determined that if other available nests were present, eastern bluebirds would occupy a new unoccupied cavity to avoid soiled nests and parasites present within the cavity. The authors concluded that the variance in cavity depth support the variation in nest heights throughout the breeding season. This study was conducted to provide further knowledge on the habitat requirements of eastern bluebirds and their behavioral methods when determining an optimal nesting site. Multiple variances that were examined by the authors allowed for a greater understanding of the way eastern bluebirds select their nesting cavities throughout the breeding season. The authors provided more insight on the behavioral plasticity of eastern bluebirds in building optimal and functional nests.

United States. Forest Service, & Scott, V. E. (1977). *Cavity-nesting birds of North American forests*. US Government Printing Office.

The purpose of this handbook is to provide insight on habitat, cavity, and food requirements for eighty-five cavity nesting species in North America.

Important characteristics such as: tree size and distribution contribute to the development of nesting cavities. Each cavity nesting species can be evaluated to view tree use, major food sources, habitat, and nest requirements. Both primary and secondary cavity nesters are described throughout the document. Description for nest boxes and cavity characteristics are documented for each species, along with their population distribution throughout the seasons and the habitats they utilize. This document

demonstrates the importance of breeding habitats being available for cavity nesters to minimize the destruction of forest areas. The authors created this document to supply land managers with current knowledge on requirements for cavity nesters to ensure that development advances and practices take into consideration the species that utilize particular habitats. The authors provide an accessible and user-friendly guide that will contribute to knowledge obtained by the audience.

Willner, G. R., Gates, J. E., & Devlin, W. J. (1983). Nest box use by cavity-nesting birds. *American Midland Naturalist*, 194-201.

The objective of this study was to determine the variance in nest boxes and habitats utilized by cavity nesters and to determine the nest box usage through a multivariate statistical model. Two study areas in Maryland were undertaken to evaluate the variance in nest box usage from secondary cavity nesters. Cavity nesting birds that utilize nest boxes at Carey Run Sanctuary were evaluated for eastern bluebirds (*Sialia sialis*), house wrens (*Troglodytes aedon*), and tree swallows (*Iridoprocne bicolor*). At Beltsville Agricultural Research Center, nest boxes for eastern bluebirds, house sparrow (*Passer domesticus*), and tufted titmouse (*Parus bicolor*) were evaluated throughout the study. There were twenty-four variables that were sampled at each nest box location before nesting season. Through various models and the discriminant function analysis (DFA) were utilized to determine nest box occupancy. After evaluating the 53 nest sites at Carey Run, it was determined that black locust and sugar maples were the common trees to surround nesting sites for all three species at Carey Run. It was determined that eastern bluebirds utilize nest boxes where herbaceous vegetation height is lower and functional equivalents, such as shrubs, saplings and trees, were at intermediate distances. Bluebirds were viewed to select regions containing poor soil quality where herbaceous plants were sparse. Tree proximity to nesting sites for house wrens was a contributor to nest selection in mixed habitats such as: wood edges, residential areas, and brushlands. Nest box entrances in loose proximity to trees were more readily used by house wrens. Tree swallows occupy open fields where higher vegetation is at maximal distance since tree swallows uses flycatching practices for foraging. The authors concluded that the correct habitat configuration and nest box placement contribute to the occupancy from bird species and that the DFA is a useful management tool to determine and evaluate nest box locations prior to installation. The authors critiqued both sampling sites but focused more on Carey Run Sanctuary since this site was where maximal nest box occupancy occurred for all species. With the habitat knowledge provided from the study, the authors have allowed for habitat selection for nest box programs to identified more readily in future studies to promote accuracy in studies and in optimal utilization of nest boxes.

Conclusion

Nesting habitat selection of cavity nesters was determined for various secondary cavity nesting species that are present within Ken Reid Conservation Area. Through this research, further knowledge was gained on nesting requirements for various secondary cavity nesters. The variables of macro and microhabitats were evaluated for wood ducks, eastern bluebirds, and tree swallows to provide knowledge on the preferred nesting habitats to install nest boxes for each species. The reproductive success of species were determined to be correlated with cavity height and cavity floor area. Habitat

requirements are major contributors to the reproductive success of breeding bird species and need to be continually studied further into depth to view other cavity nesting specie-nesting requirements.

Literature Review 4: Monitoring Bird Boxes

Sarah Sinasac

Introduction

Secondary cavity nesters are species of birds that require pre-made cavities to nest in (Miller, 2010). Often the cavities are created by other species of animals, or simply by aging trees. However, many forests are being cut down and replanted, meaning most current forests are considered new growth forests, and cavity creating species are displaced (Miller, 2010). Due to a lack of old growth forests, many secondary cavity nesters are habitat limited, and therefore declining in population abundance (Wetzel and Krupa, 2013). Due to the decline in many secondary cavity nesters' populations, the popularity of using nest boxes as replacement habitat has risen (Shutler et al., 2012). However, in order to determine the suitability and occupancy of nest boxes, the boxes must be monitored (Corrigan et al., 2011). Insects or mammal pests can infest nest boxes, or the boxes can become too dirty for inhabitation, or simply become destroyed from use (Lidenmayer et al., 2009). The boxes require monitoring effort through human labour, or through technology such as video cameras (Peirce and Pobprasert, 2007). Nest boxes are often used as replacement habitat, and therefore should be monitored for occupancy rate in order to ensure that the boxes are an effective conservation method for the species (Libois et al., 2012).

Secondary cavity nesters require nest boxes to provide suitable habitat and monitoring to ensure nest box durability and species' safety from predators.

Corrigan, R.M., Scrimgeour, G.J., and Paszkowski, C. (2011). Nest boxes facilitate local-scale conservation of Common Goldeneye (*Bucephala clangula*) and Bufflehead (*Bucephala albeola*) in Alberta, Canada. *Avian Conservation and Ecology* 6(1), 1-18.

This article experimented with nest boxes in the Prairie Pothole region in Alberta, focusing mainly on breeding waterfowl. It has been found that roughly 80% of the prairie pothole region has had habitat loss due anthropogenic reasons. Habitat loss typically leads to a loss in biodiversity, often meaning a loss of the species that create cavities that secondary cavity nesters use. Therefore, there has been a decline in suitable cavities for secondary cavity nesters, such as waterfowl, to use. Corrigan et al. believed that the placement of nest boxes in areas that have seen significant habitat loss, would lead to a local increase in waterfowl species, but not necessarily a regional increase. Nest boxes were placed within wetlands in 1989 and 1991, and were manipulated experimentally over the years to determine how the waterfowl would respond. Boxes were created with removable sides so that the species within could be monitored. Different sized boxes were placed in wetlands for different species. In order to manipulate the experiment, certain boxes were closed in the winter/spring by nailing up the entrance hole with a piece of plywood. Corrigan et al. found that a large number of the nest boxes became occupied, and the percentage of occupied boxes increased the longer the boxes were in the wetland.

Corrigan et al. also found that by closing nest boxes, the brood sizes would be greatly decreased. Therefore, Corrigan et al. determined that the waterfowl species in the prairie pothole region in Alberta are greatly limited by the number of cavities within the habitat. This article provided information on the importance of nest boxes for cavity nesters, and showed how nest boxes can increase the abundance of particular species within a local area.

Libois, E., Gimenez, O., Oro, D., Minguéz, E., Pradel, R., and Sanz-Aguilar, A. (2012). Nest boxes: a successful management tool for the conservation of an endangered seabird. *Biological Conservation* 155(1): 39-43.

This article is about using nest boxes as a form of protection for endangered birds. The Mediterranean Storm Petrel is found on islands in Spain and is predated upon by gulls. For seabirds, it is easier to concentrate conservation efforts on breeding grounds rather than at sea, and Libois et al. hoped to help conserve Storm Petrels by placing nesting boxes in their breeding grounds. The Storm Petrels in this study breed within caves at high numbers, so breeding birds were captured out of the caves and banded. Monitoring began in 1993, and bird boxes were established in 1996. Monitoring of all sites continued until 2012. Capture-recapture models were used to estimate survival, recapture and change of nest type probabilities at one of the two cave sites. Libois et al. found that placing nest boxes within the breeding grounds of the Storm Petrel increased reproductive success and even improved adult survivorship. Libois et al. also found that predation rates were lower on the sites with bird boxes than on the sites with only natural nests. This article is beneficial to this literature review because it discusses a method of monitoring bird boxes, and discusses the benefits of using bird boxes to help conserve endangered species.

Lidenmayer, D.B., Welsh, A., Donnelly, C., Crane, M., Michael, D., Macgregor, C., McBurney, L., Montague-Drake, R., and Gibbons, P. (2009). Are nest boxes a viable alternative source of cavities for hollow-dependent animals? Long-term monitoring of nest box occupancy, pest use and attrition. *Biological Conservation* 142(1), 33-42.

This article is about a nest box study in a Mountain Ash forest in Australia over 10 years, focusing on marsupials that inhabit the nest boxes. Lidenmayer et al. question if nest boxes are the most economically sound option within the area, or if finding a way to increase natural cavities within trees would be a better option. Many logged forests lack the proper number of cavities within the trees, since all old trees are removed. Lidenmayer et al. focused their study on marsupials, but also studied how often nest boxes are infected with insect pests and therefore need to be serviced. Lidenmayer et al. began their study by choosing two forests, both of which are used for sivilcultural practices, and established six sites within each forest. Each site was 20m by 20m, and one nest box was placed in the corners of each site (4 boxes per site). Two different sizes of nest boxes were used, to target different species. Nest boxes were each checked manually 15 times through the study period. Lidenmayer et al. found that a higher percentage of nest boxes in the younger forest (58%) were occupied compared to the older growth forest (4%). Lidenmayer et al. also found that a large percentage (33%) of the boxes in the new growth forest became infested with pests (mainly European honeybees). Lidenmayer et al.

concluded that nest boxes are useful for conservation practices in new growth forests. This article is beneficial to this literature review because it discusses the monitoring of nest boxes in a different country. Even though the animals using the nest boxes are not birds, there is still a similar need for nest boxes, and a similar method of monitoring the boxes.

Micheal, J.M. (2010). Differential fledging production for tree swallows using nest boxes in two artificial and seemingly different environments in western Washington. *Northwestern Naturalist* 91(1), 91-94.

Micheal installed nest boxes for tree swallows at two sites in western Washington, near a constructed wetland. The purpose of this study was to determine if the constructed wetland had a positive or negative impact on the tree swallow populations. The nest boxes at one site were monitored for seven years, while the nest boxes at the second site were monitored for 12 years. Micheal remotely observed boxes every couple of days, and would actively check the boxes weekly. Any young birds found within the boxes were banded. Boxes were manually cleaned after each brood. Michael found that tree swallows very heavily used the boxes, with 100% occupation at some points in the study. The boxes were also used by other species of birds throughout the study time period. Micheal found that boxes located closer to water had a higher success rate than those located further away. This article shows that monitoring of nest boxes can be done by one person and does not have to be labour intensive. Boxes can be monitored using binoculars, along with manual checks.

Miller, K.E. (2010). Nest site limitation of secondary cavity nesting birds in even-age southern pine forests. *The Wilson Journal of Ornithology* 122(1): 126-134.

This article is about Miller's experiments with nest site availability in a southern pine forest in Florida, USA. Nesting sites can limit cavity nester's reproductive success, and past research has found that newer forests typically have less cavity nesting sites than older forests. Cavity nests are also found to be more abundant in forests with deciduous hardwood trees rather than coniferous trees. Therefore, Miller hypothesized that the southern pine forest would be cavity limited. The author set up 12 sites in a 35 year old forest, placing the sites throughout different soil and vegetation communities. Miller placed a total of 320 nest boxes, with dimensions suitable for all cavity nesters in the area, on eight of the experimental plots. Nests were monitored every 3-4 days and boxes were monitored every 10-14 days using a ladder to inspect the inside of the boxes and the nests. The intensive point count method was used to estimate bird densities. Counts were conducted within 3 hours of sunrise, and the birds were counted for nine minutes each time. Miller conducted all counts to eliminate any bias. Most of the studied species of birds had a positive reaction to the placement of the next boxes. Eastern bluebirds were not found on the sites until nest boxes were placed there, meaning that the number of cavities limited the bluebirds. This article highlights a potential way to monitor birds without using extensive technology, however, it is a labour heavy method and requires many early morning trips to the experimental plots.

Peirce, A.J., and Pobprasert, K. (2007). A portable system for continuous monitoring of bird nests

using digital video recorders. *J. Field Ornithol.* 78(3): 322–328.

This article is about a monitoring system that Peirce and Pobprasert created to monitor bird nests and boxes. Many nests and boxes are monitored using video recording devices, however, often devices are too slow or bulky, or involve countless hours of video reviewing. Peirce and Pobprasert designed a video recording system that was relatively inexpensive (under 700 dollars), easy to transport, and could video record for long periods of time. A system was created that attached a camera to a power dock that was attached to a 12-volt battery. The camera was placed in a camouflage box and attached to a tree 2.5-5 m from the nest. The camera had to be placed low enough in the tree that predators would not use it as a potential perch site. All files from the cameras were recorded onto DVDs to decrease the storage effort that was originally needed with VHS tapes. Peirce and Pobprasert found that their method of monitoring nests was satisfactory, and resulted in very little disturbance of the nest, as the cameras took very little time to set up. Peirce and Pobprasert were able to record 249 days of 32 different nests, monitoring nest predation. Peirce and Pobprasert were not able to determine if the cameras had an effect (negative or positive) on nest predation, but they found that any animals passing the cameras did not change their behavior. This article outlines an effective method of nest monitoring using technology to continuously monitor many nests.

Ransom, D.J., and Frentress, C.D. (2007). Monitoring Texas wood ducks with a cooperative nest-box program. *The Journal of Wildlife Management* 71(8), 2743-2748.

This article looks at the data collected over eight years by Texas Parks and Wildlife (TPW) on wood duck nest box usage. TPW began a nest box program in 1988, allowing any cooperator to receive a free nest box for their property, as long as the box was monitored every year. This article aims to organize and quantify all data collected by any involved in the project. All cooperators were told to monitor their nest boxes for signs of nesting including down feathers, eggshells, and unhatched eggs. Ransom and Frentress had trouble interpreting the data, as not all forms were filled out consistently, and often data on how many eggs were found was not included. Ransom and Frentress calculated nest box use and nest box success for each year, for the state of Texas. Ransom and Frentress found that the monitoring system set up by the TPW was not as effective as monitoring by a single user or group would be. Ransom and Frentress found that nest box success was high throughout Texas; however, they suggested that more accurate monitoring would be needed to fully determine success rate. Overall, this article shows that while engaging the public in monitoring could be helpful, it is difficult to ensure that all data is consistent. Therefore, data collected by the public may not be useable in scientific studies of the species.

Shutler, D., Hussell, D.J.T., Norris, D.R., Winkler, D.W., Robertson, R.J., Bonier, F., Rendell, W.B., Belisle, M., Clark, R.G., Dawson, R.D., Wheelwright, N.T., Lombardo, M.P., Thorpe, P.A., Truan, M.A., Walsh, R., Leonard, M.L., Horn, A.G., Vleck, C.M., Vleck, D., Rose, A.P., Whittingham, L.A., Dunn, P.O.,

Hobson, K.A., and Stanback, M.T. (2012). Spatiotemporal patterns in nest box occupancy by tree swallows across North America. *Avian Conservation and Ecology* 7(1), 3-12.

This article is about the changing populations of insectivorous birds within North America, with a focus on nest box populations of tree swallows. Data has shown that tree swallow populations in eastern North America are decreasing, and therefore are in great need for conservation efforts. Researchers monitor many tree swallow nest box sites, so Shutler et al. compiled research from 16 tree swallow nest box sites. The sites were distributed throughout North America. Researchers visited the sites at least once a week at the beginning of the breeding season, which is usually April-May. Some of the sites had monitoring data ranging 1947 until present day, while some only had data from 2004 to present. Shutler et al. recorded the number of boxes available at each site, and the number occupied each year. Data was analyzed using regression slopes, and significant increases and decreases in box occupancy were determined. Shutler et al. found that 86% of the sites in eastern North America had significant decreasing population trends. However, only one of the sites in western North America had a significant decreasing population trend. Shutler et al. concluded that the decrease in box occupancy rates in eastern North America likely represent a decrease in tree swallow population size. Tree swallows will benefit from continued monitoring and continued conservation efforts. This article shows that nest boxes provide an effective conservation technique, but providing nests may not be enough effort to fully conserve a declining species.

Wetzel, D.P., and Krupa, J.J. (2013). Where are the bluebirds of the bluegrass? Eastern bluebird decline in Central Kentucky. *The American Midland Naturalist* 169(2), 398-408.

This study found that eastern bluebird populations across Central Kentucky have been decreasing, even though most other North American populations have been increasing. Wetzel and Krupa decided to investigate different potential reasons for the decline in population. Bluebird populations had been decreasing across North America until the 1970s and 80s, when people became interested in the fate of the bluebirds, and began erecting bird boxes in suitable habitats. Wetzel and Krupa investigated the decline in bluebird population by comparing research from the Christmas Bird Count, and the Breeding Bird Survey to potential reasons for the decline. Wetzel and Krupa believed that the decline in Central Kentucky might be due to a regionally specific reason. They also set up an experimental site at the university of Kentucky in 2007, and placed 52 nest boxes in suitable bluebird habitat. The boxes were checked every two weeks for breeding birds and eggs. Wetzel and Krupa focused on boxes inhabited by bluebirds, but also studied boxes inhabited by other cavity nesters. Wetzel and Krupa compared the data collected from the bird boxes to climatic data from the previous winters, to determine if the previous winter's harshness had an impact on bluebird occupancy rate. Past bluebird population declines have been related to extreme winter weather. Wetzel and Krupa decided through their research that the most likely reason for the decline of bluebirds in Central Kentucky was the winter weather. This article showed that while some populations of species of birds may be doing well and increasing, regional populations may not be doing well, and may need conservation.

Conclusion

Almost all studies shown in this literature review found that cavity-nesting birds are limited by

the availability of cavities. Therefore, most bird populations increased locally with the placement of nest boxes in suitable habitats. Often bird boxes can have up to 100% occupancy rates within limited habitat areas. Bird boxes should always be monitored, and monitoring efforts often involve personal visits to the boxes weekly during breeding season. Occasionally monitoring efforts involve technological devices, but these devices are often expensive. Nest boxes can become infected by pest species, mainly insects, and should be checked for damage often. Overall, nest boxes were found to be an effective method of conserving secondary cavity nesting species, however in some cases, nest boxes were not enough. All species of cavity nesters would benefit from extra concern and extra conservation efforts.